

HiFi ENGINE[®]

For more Hi-Fi manuals and set-up information
please visit www.hifiengine.com

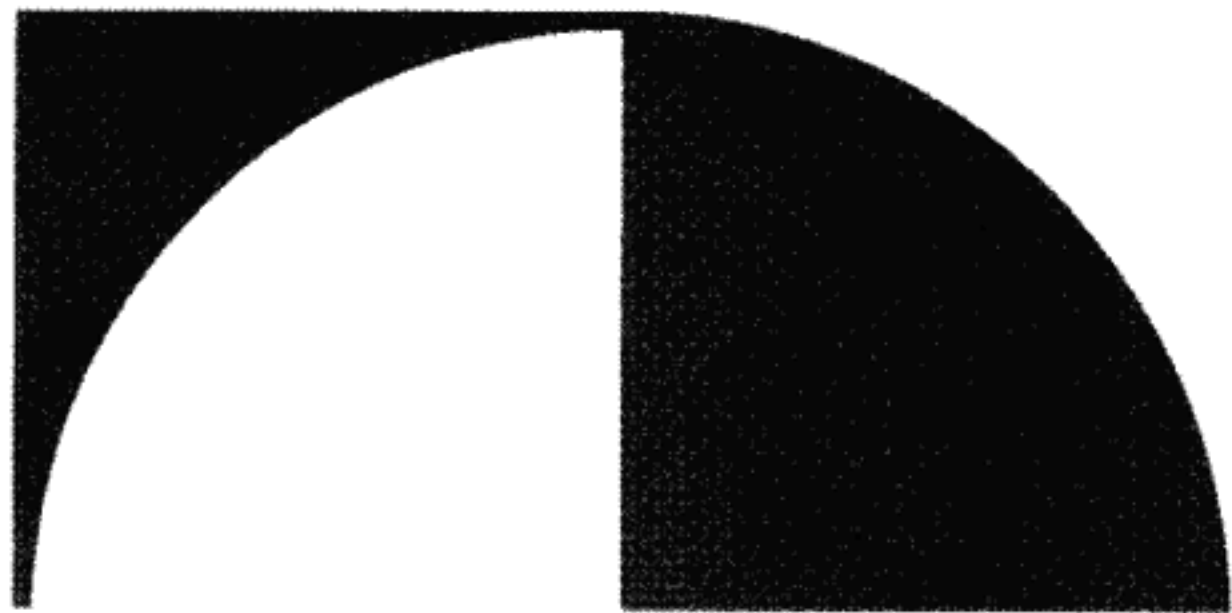

Nakamichi 582Z

Discrete Head Cassette Deck

Owner's Manual

WARNING

TO PREVENT FIRE OR SHOCK
HAZARD, DO NOT EXPOSE
THIS APPLIANCE TO RAIN OR
MOISTURE.

Please record the Model Number and Serial Number in the space provided below and retain these numbers.

Model Number and Serial Number are located on the rear panel of the unit.

Model Number: Nakamichi 582Z

Serial Number: _____

CONTENTS

Safety Instructions	1
On Cassette Tapes	2
Precautions	2
Controls and Features	3
Connections	5
Playback	6
Before Recording	7
Matching the Cassette Deck to Various Cassette Tapes	7
Dolby Noise Reduction System	9
Recording	11
Timer Operation	11
Tips on Setting Record Levels	13
Maintenance	14
Troubleshooting	16
Specifications	17

Congratulations!

You have chosen one of the most advanced cassette decks on the market today. The 582Z is a grade-up model based on the 582, which has won world-wide acclaim and is used for cassette tape measurements and as a reference deck by tape makers and testing laboratories all over the world.

The 582Z has new 50 dB wide range level indicators, but its greatest innovation is in the field of noise reduction: besides the common Dolby B-Type NR, it incorporates the Dolby C-Type NR system. This revolutionary noise reduction system makes possible hitherto unknown tape performance and guarantees superb sound without the limitations of previous systems.

Of course, the basic policy and superior technology of the 582 have been retained. Built-in 400 Hz and 15 kHz oscillators, facilities for bias and Dolby level adjustments etc. give you perfect control to extract the best from every tape. This is truly a machine dedicated by Nakamichi to the demanding tape enthusiast.

Nakamichi products are internationally famous for state-of-the-art engineering and manufacture — assurance that your 582Z will bring you many years of reliable service and enjoyment.

Many of the 582Z's controls and features may be unfamiliar to you at the moment. This manual has been designed to acquaint you with the 582Z in the shortest possible time. Please take the time to read it in its entirety.

Thank you.

Nakamichi Corporation.

Safety Instructions

The following safety instructions have been included in compliance with safety standard regulations. Please read them carefully.

1. **Read Instructions**-All the safety and operating instructions should be read before the appliance is operated.
2. **Retain instructions**-The safety and operating instructions should be retained for future reference.
3. **Heed Warnings**-All warnings on the appliance and in the operating instructions should be adhered.
4. **Follow Instructions**-All operating and use instructions should be followed.
5. **Water and Moisture**-The appliance should not be used near water-for example, near a bathtub, washbowl, kitchen sink, laundry tub, in a wet basement, or near a swimming pool, etc.
6. **Carts and Stands**-The appliance should be used only with a cart or stand that is recommended by the manufacturer.
7. **Wall or Ceiling Mounting**-The appliance should be mounted to a wall or ceiling only as recommended by the manufacturer.
8. **Ventilation**-The appliance should be situated so that its location or position does not interfere with its proper ventilation. For example, the appliance should not be situated on a bed, sofa, rug or similar surface that may block the ventilation openings; or placed in a built-in installation, such as a bookcase or cabinet that may impede the flow of air through the ventilation openings.
9. **Heat**-The appliance should be situated away from heat sources such as radiators, heat registers, stoves, or other appliance (including amplifiers) which produce heat.
10. **Power Sources**-The appliance should be connected to a power supply only of the type described in the operating instructions or as marked on the appliance.
11. **Grounding or Polarization-Precautions** should be taken so that the grounding or polarization means of an appliance is not defeated.
12. **Power-Cord Protection**-Power-supply cords should be routed so that they are not likely to be walked on or pinched by items placed upon or against them, paying particular attention to cords at plugs, convenience receptacles, and the point where they exit from the appliance.
13. **Cleaning**-The appliance should be cleaned only as recommended by the manufacturer.
14. **Nonuse Periods**-The power cord of the appliance should be unplugged from the outlet when left unused for a long period of time.
15. **Object and Liquid Entry**-Care should be taken so that objects do not fall and liquids are not spilled into the enclosure through openings.
16. **Damage Requiring Service**-The appliance should be serviced by qualified service personnel when:
 - A. The power-supply cord or the plug has been damaged; or,
 - B. Objects have fallen, or liquid has been spilled into the appliance; or,
 - C. The appliance has been exposed to rain; or,
 - D. The appliance does not appear to operate normally or exhibits a marked change in performance; or,
 - E. The appliance has been dropped, or the enclosure damaged.
17. **Servicing**-The user should not attempt to service the appliance beyond that described in the operating instruction. All other servicing should be referred to qualified service personnel.

On Cassette Tapes

Precautions

Precautions

1. C-120 cassettes (playing time one hour per side) contain extremely thin tape which breaks or snarls easily, is sometimes subject to stretching and has low sensitivity. Therefore, C-120 cassettes are not recommended for high-fidelity recording.
2. Do not pull out the tape from the cassette housing.
3. Be careful not to turn the cassette reels with the fingers, causing tape slackening.
4. Store cassette tapes away from heat, high humidity, dust, and magnetic fields such as caused by speakers, TV sets etc.

Cassette Tabs

You can protect valuable recordings from accidental erasure by completely removing the appropriate tab on the top edge of the cassette. Use a small screwdriver and push the tab down to break it off. Do not leave the broken tab in the recess. When the tab is removed, the deck will not record or erase this side of the cassette, even if the record button is pushed. When wanting to record again on this side at a later date, simply cover the tab opening with a piece of adhesive tape.

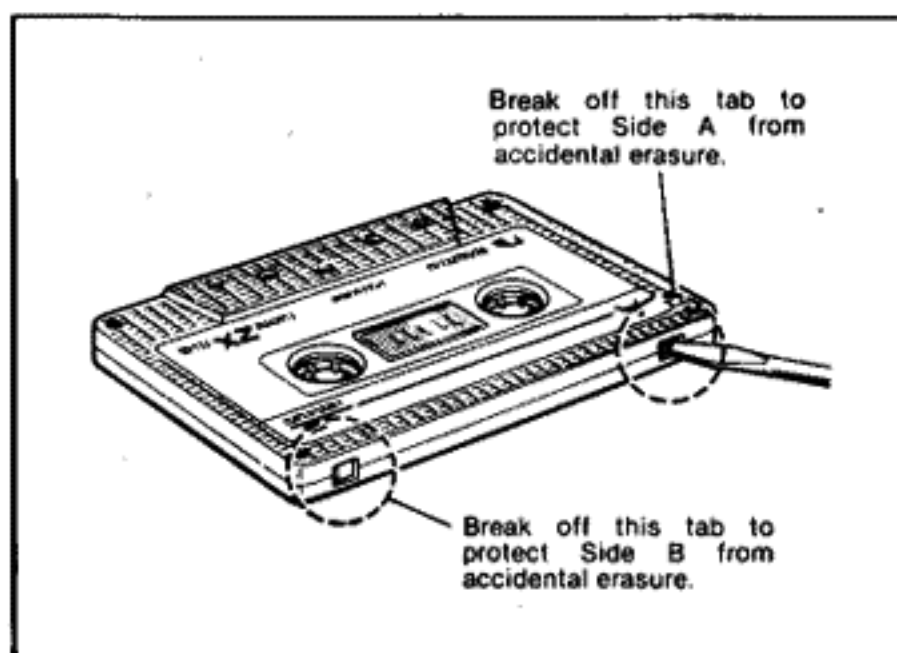

Insertion and Removal

(1) Insertion of a Cassette

1. Push the eject button to open the cassette compartment.
2. Insert the cassette into the compartment from the top. Make sure that the exposed tape is facing down and the label of the desired side is facing you.
3. Close the cassette holder by gently pushing it back into the panel.

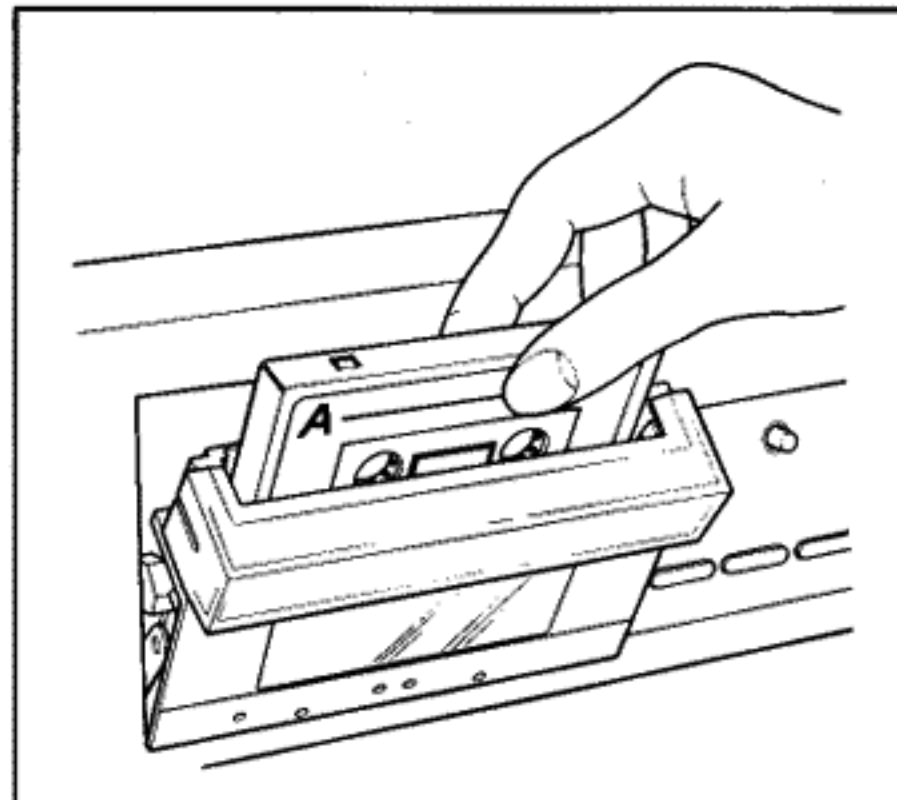

(2) Removal of a Cassette

1. Press the stop button.
2. Open the cassette compartment by pushing the eject button.
3. Remove the cassette.

1. Make sure the memory/timer switch is set to "off" or "Memory" when you do not desire the self-starting feature. Should this switch be accidentally left in the "rec" position, you will begin recording merely by turning on the power switch. A cassette tape already in the compartment and without its protective tabs removed will be erased in such instances. Although this may be an unlikely occurrence, you can eliminate the possibility of such accidental erasure by observing this precaution.
2. Make sure the test tone switch is set to "off" (center position) for normal recording or playback. The test tone oscillator overrides the input to the 582Z during record, and in the "400" or "15 k" position there is a shift in meter range, making playback readings inaccurate.
3. The 582Z incorporates a special circuit designed to take up any loose tape inside the cassette when it is inserted. The moment you push the cassette holder into the compartment, the take-up spindle will rotate several times, also if the holder is closed without a cassette inserted. This behavior is normal and not a fault with the deck.

Controls and Features

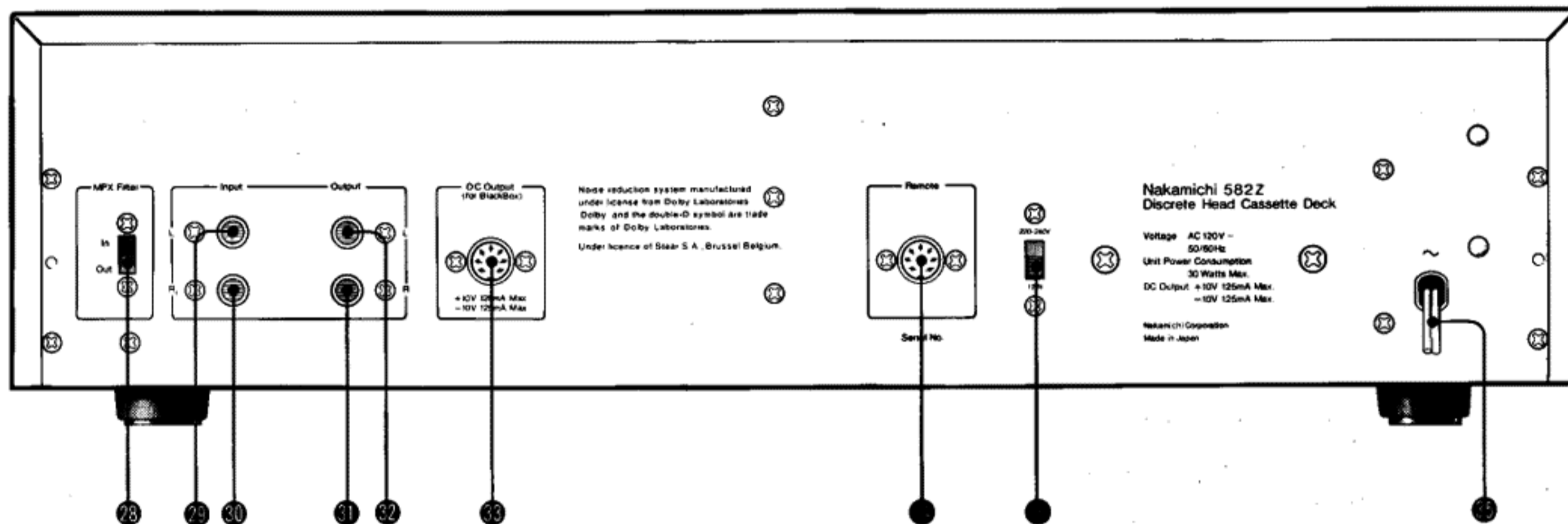
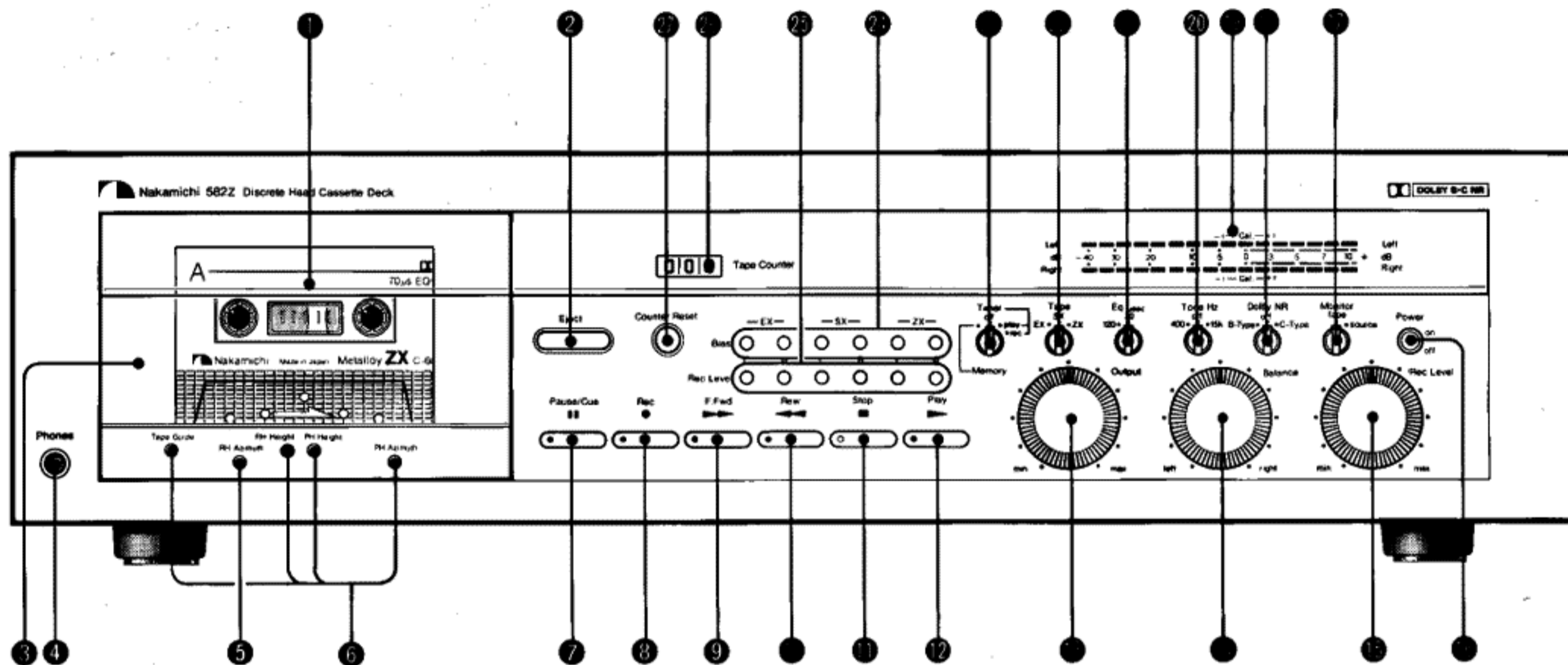

(1) Acrylic Cassette Compartment Cover
Can be easily detached to allow access to the heads, capstans and pressure rollers for routine maintenance. (→p. 14)

(2) Eject Button
Press to eject the cassette. The cassette lid will withdraw smoothly thanks to a built-in pneumatic damper. It is not possible to eject the cassette while the transport is in any mode other than "stop".

(3) Cassette Lid
Ensures proper alignment of the cassette for insertion. See-thru design provides an unobstructed view of the cassette, once inserted.

(4) Headphone Jack
Accepts standard 1/4-inch diameter stereo phone plug.

(5) Record Head Azimuth Alignment Screw
This screw has been adjusted at the factory for optimum performance. However, cassette tape housing variations may cause the need for re-adjustment (→p.12).

(6) Head Height and Azimuth Alignment Screws
These adjustments have been calibrated at the factory for optimum performance. DO NOT ATTEMPT RE-ADJUSTMENT. These adjustments should only be made by qualified service technicians.

(7) Pause/Cue Button

(8) Record Button

(9) Fast-Forward Button

(10) Rewind Button

(11) Stop Button

(12) Play Button

(13) Output Level Control

Controls the output level of the 582Z during record and playback.

(14) Balance Control

Controls the relative balance between the left and right inputs.

(15) Input Level Control

Controls the input (record) levels for the left and right channels simultaneously.

(16) Power Switch

Activates the 582Z. The level meters and cassette compartment will illuminate to indicate that power is "on".

(17) Monitor Switch

Selects either the input signal ("source") or the playback signal ("tape") for monitoring during record.

(18) Dolby NR Switch

Serves to select either the Dolby B-Type NR, which affords appr. 10 dB of noise reduction in the high frequencies, or the Dolby C-Type NR, which provides appr. 20 dB of noise reduction. (→p. 9)

(19) Level Meters

Indicate peak program levels from -40 to +10 dB.

(20) Test Tone Switch

Selects and activates one of two built-in test tone oscillators: 400Hz @ 0 dB, or 15 kHz @ -20 dB.

(21) Eq Switch

Selects either 120 or 70 microsecond equalization.

(22) Tape Switch

Selects required record sensitivity and bias level for three different tape types: EX (low-noise/high-output ferric oxide), SX (chrome-equivalent), and ZX (metalloy).

(23) Tape Start Memory/Timer Switch

The "Memory" position enables the deck to "remember" any starting point on the tape. Set the tape counter to 000 at the desired point, and the 582Z will automatically stop from the rewind mode when the counter reaches 999. The "Timer" positions are used for unattended recording or playback at a pre-selected time. An external timer is required for the latter feature. (→p. 11)

(24) Bias Adjustment Controls

Screwdriver adjustments for record bias current. Bias adjustments can be performed using the 582Z's built-in 15 kHz test tone. (→p. 7)

(25) Record Calibration Controls

Screwdriver adjustments for record level calibration, essential for proper tracking of the Dolby Noise Reduction circuits. These controls are adjusted using the built-in 400 Hz test tone. (→p. 10)

(26) Tape Counter

Indicates relative position of the tape. May be used to index selections on the tape.

(27) Counter Reset Button

Resets the tape counter to 000 when fully depressed.

(28) MPX Filter Switch

Used to switch an MPX filter, which prevents the 19 kHz multiplex carrier signal from interfering with Dolby operation when recording from FM stereo broadcasts.

(29) Left Input Jack

(30) Right Input Jack

(31) Right Output Jack

(32) Left Output Jack

(33) DC Output Jack

Provides a regulated ± 10 Volts DC to power one or more of Nakamichi's BlackBox Series components, such as the MX-100 Microphone Mixer. Total current consumption of BlackBox components powered from this jack must not exceed 125 mA. (→p. 5)

(34) Remote Control Socket

The optional RM-200 Remote Control unit is plugged into this socket.

(35) Power Cord

(36) Voltage Selector

AC voltage is factory set for the country in which the 582Z is sold. The voltage selector permits re-setting of mains voltage in case the deck is to be used in a different country. Note:

Safety regulations in certain countries prohibit inclusion of a voltage selector.

This feature, therefore, may be absent from your deck.

Connections

Connection of amplifier and remote control

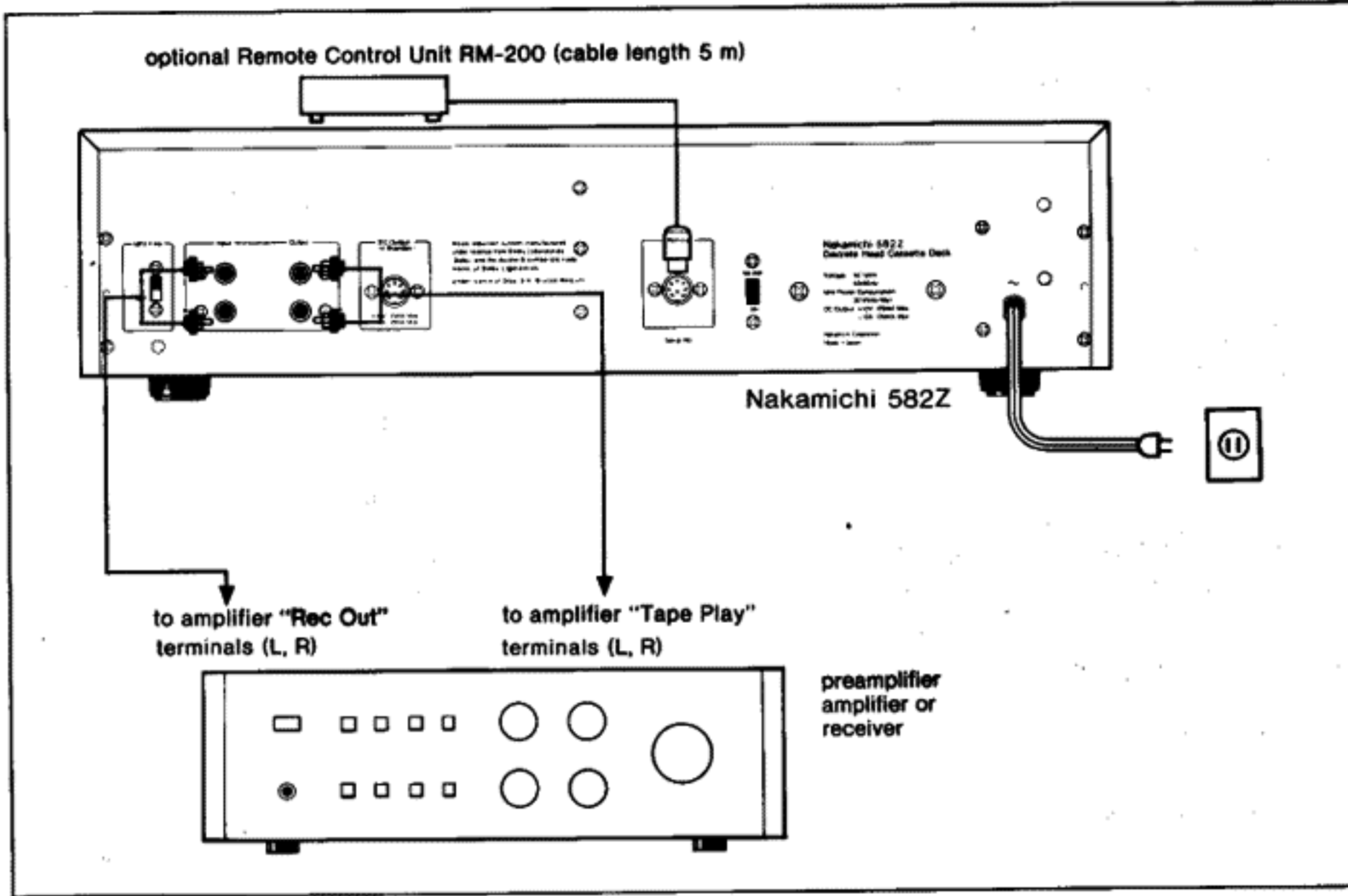

Headphones

Standard stereo headphones may be connected to the headphone jack on the 582Z's front panel. Low impedance headphones (8 ohms nominal) are recommended.

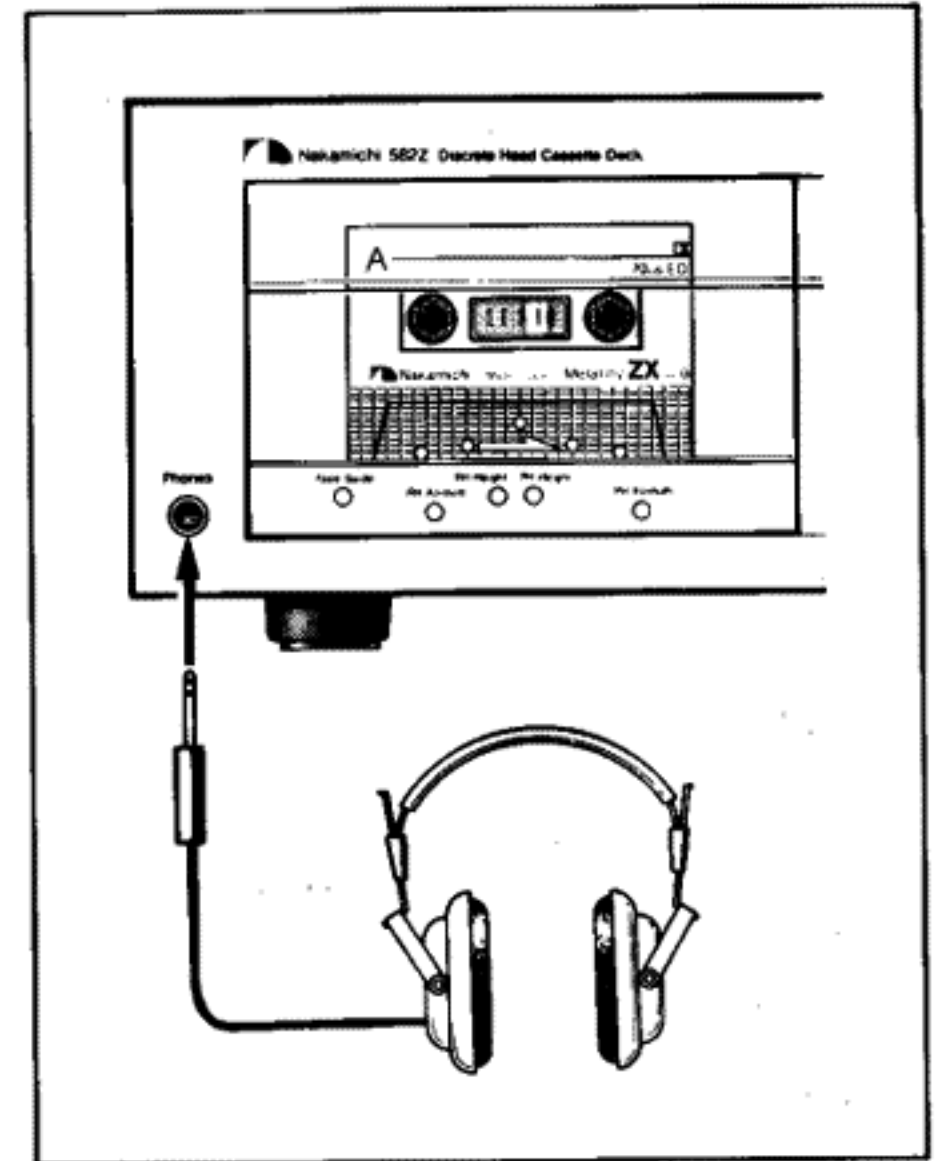

Nakamichi BlackBox Series Components

The 582Z provides a rear panel connector which can be used to power one or more of Nakamichi's BlackBox Series accessories. The DC output jack supplies a regulated ± 10 Volts DC and thus eliminates the need for the separate PS-100 Power Supply, which is normally used to power the BlackBox components. Although this jack can be used to power any Nakamichi BlackBox component, the following one has the greatest potential application for the 582Z.

MX-100 Microphone Mixer

Since the 582Z has no built-in microphone preamplifiers, an external microphone mixer must be used for "live" recordings. The MX-100 provides three mic inputs (left, right and center "blend") with low noise and unusually wide dynamic range. It is particularly well-suited for applications of Nakamichi's tri-microphone live recording system. Nakamichi publishes a booklet on live recording, available on request, for those who wish to pursue the subject in further detail.

Note:

The table below gives the maximum current consumption ratings for each of the BlackBox components. Refer to this table to calculate which and how many BlackBox units can be powered by the 582Z. Under no circumstances connect BlackBox units exceeding 125 mA in total current consumption.

If you wish to use multiple BlackBox components which exceed 125 mA in total current consumption, please purchase a PS-100 Power Supply. The instruction booklets supplied with individual BlackBox Series components should be consulted for additional information.

BlackBox Component	Current Rating
EC-100 Electronic Crossover	100 mA
MX-100 Microphone Mixer	50 mA

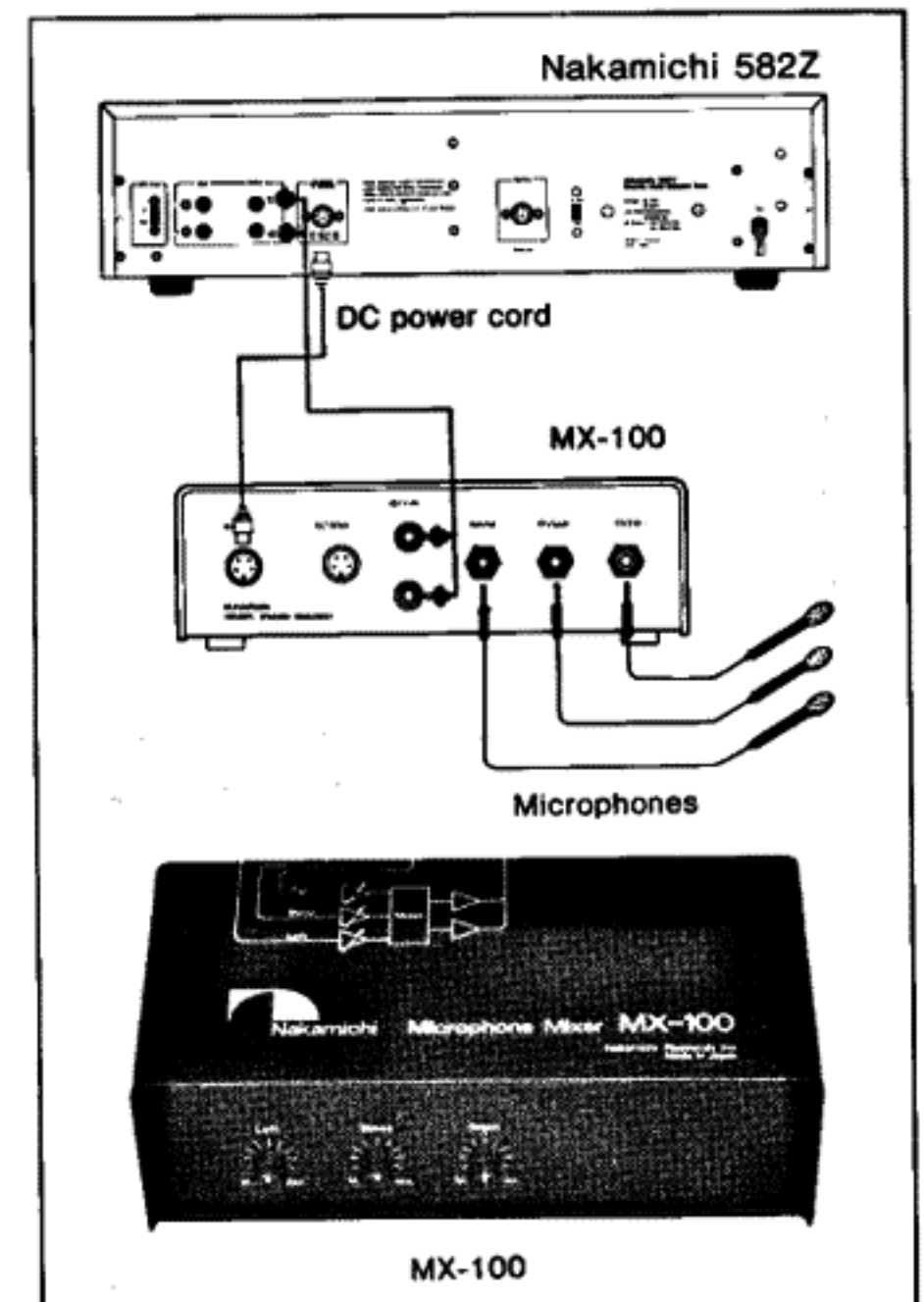

- ① After confirming that the tape start memory/timer switch is set to "off" or "Memory", turn on the power by pushing the power switch.
- ② Open the cassette compartment lid by pushing the eject button.
- ③ Load the cassette into the lid from the top. Then, close the cassette lid by pushing it gently back into the panel.
- ④ Set the monitor switch to the "tape" position.
- ⑤ Set the Eq switch to the required position — either 120 or 70 microseconds. (→p. 7)
- ⑥ Make sure that the test tone switch is set to "off". If it is set to "400" or "15k", the level meter's sensitivity is increased and playback levels are not indicated correctly.
- ⑦ When playing back a tape which was recorded with Dolby B-Type noise reduction, set the Dolby NR switch to "B-Type". When playing back a tape which was recorded with the Dolby C-Type noise reduction, set the Dolby NR switch to "C-Type". Except for tapes recorded with C-Type noise reduction, ordinary Dolby-encoded tapes must be played back in the "B-Type" position.
- ⑧ Press the play button to start the tape.
- ⑨ Adjust the desired level with the output level control.
- ⑩ To stop the tape momentarily, press the pause/cue button. To resume playback, press the play button again.
- ⑪ To stop the tape altogether, press the stop button.
- ⑫ After the tape has stopped, you may eject it by pushing the eject button.

Note:

- You cannot eject the cassette while the tape is in motion.
- When the tape reaches its end, or if a defect within the cassette impedes tape motion, the 582Z's logic circuitry will return the transport to the stop mode automatically.
- Logic circuitry prevents operation of the transport when the cassette lid is open.
- You need not press the stop button when going from one transport mode to another (for example, from rewind to fast-forward).
- During playback, the peak level meters indicate the levels of the signals recorded on the tape. The output level control will affect volume, but it will have no effect on meter readings.

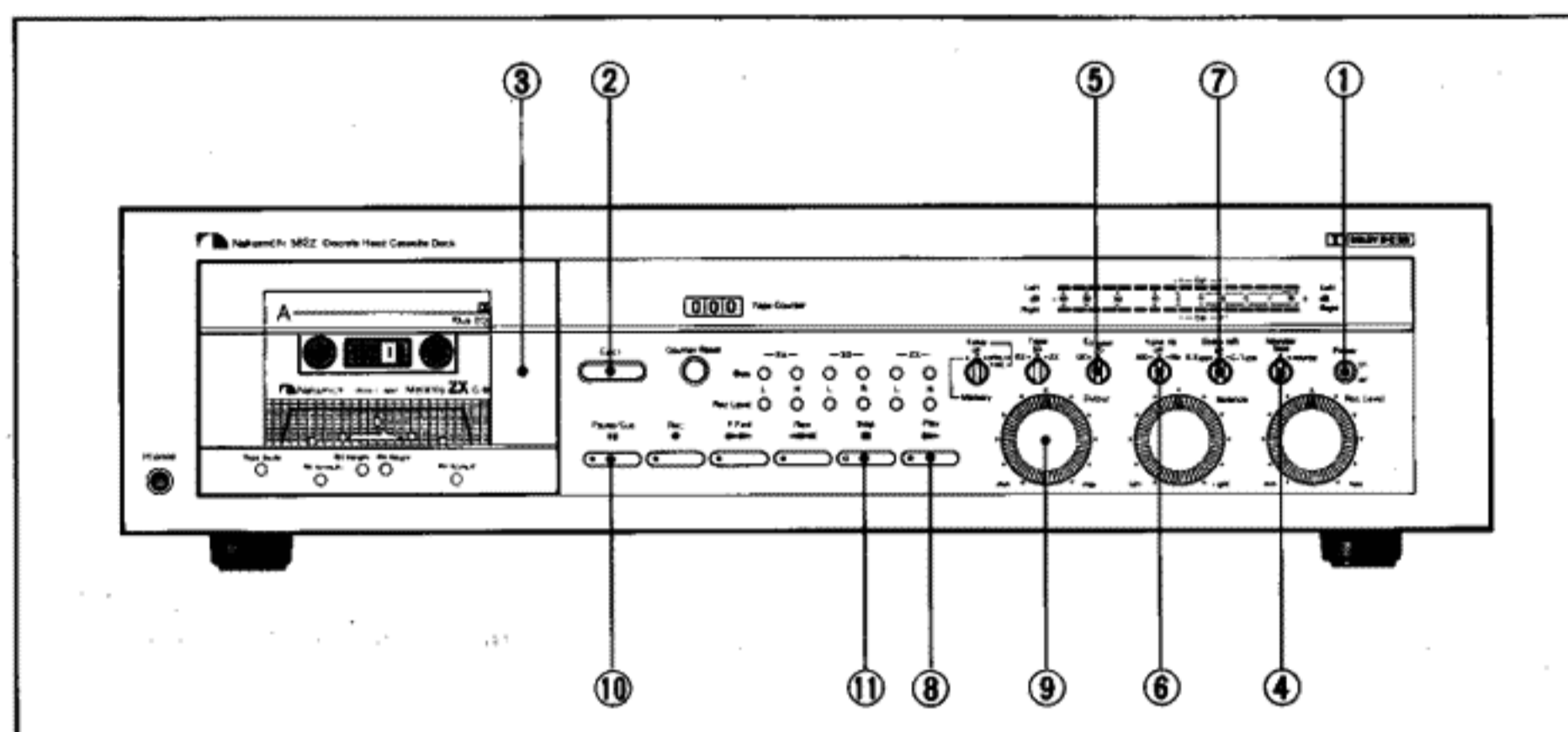

- If you find the meter readings excessively high, you probably have the test tone switch set to "400" or "15 k". It should be "off".

Cueing

When the tape is shuttling during rewind or fast-forward, the head assembly is normally retracted and the output muted so that you do not hear the unwanted, high-pitched sounds that would otherwise result. But these high-pitched signals, if somewhat reduced in speed, can be used to locate the blank spots which mark the end of one selection and the beginning of the next. Most professional open-reel tape decks offer just such a feature. It is called cueing.

The 582Z provides a unique feature quite similar to cueing systems found on professional equipment. While you are in rewind or fast-forward, you can hear the tape in high-speed motion by pressing the pause button. Pressing this button while the deck is fast-winding will move the playback head closer to the tape and reduce winding speed to one-third. You can further reduce winding speed to approximately one-fifth by pressing and holding the rewind button or the fast-forward button. If you have moved the tape too far in one direction, you can change the direction of tape travel while remaining in the cueing mode simply by pressing the opposite fast-winding button. Pressing both the rewind and fast-forward buttons simultaneously will stop the tape with the deck remaining in the cueing mode. By making use of these features, you can easily locate any desired starting point on the tape. Pressing the stop button or the play button will release the cueing mode.

Before Recording

Matching the Cassette Deck to Various Cassette Tapes

There are many brands of cassette tapes, which can be generally divided in three types: "chrome" tape formulations, "normal" tape formulations and "metal" tape formulations (such as Metalloy-Nakamichi ZX tape, etc.). When using "chrome" type tapes, set the tape switch ("Tape") to "SX" and the Eq Switch ("Eq") to "70 μ s"; for "normal" type tapes set the tape switch to "EX" and the Eq switch to "120 μ s"; and for "metal" type tapes set the tape switch to "ZX" and the Eq switch to "70 μ s". (This deck is not suited for use with ferrochrome -FeCr- tapes.)

Head Configuration

In order to obtain the best parameters for each function, this deck possesses a wide-gap recording head and a narrow-gap playback head. Erase head, record head and play head are arranged in Nakamichi's unique completely discrete 3-head configuration, which permits off-the-tape monitoring during recording and lets you perform the various adjustments most easily, using a test tone.

Tape Switch ("Tape") and Equalizer Switch ("Eq") Settings

In order to fully realize the potential of this cassette deck, you should use cassette tapes from the list below, wherever possible.

Tape Switch ("Tape")

This switch serves to select the required bias current for different tape types. If the bias current is too low, high frequency response as well as distortion rise. If it is too high, high frequency response as well as distortion decrease. This deck is adjusted to give best results with Nakamichi SX, EX II and ZX tapes at the respective positions.

Equalizer Switch ("Eq")

In order to match the deck to the characteristics of the tape, besides bias it is necessary to adjust the equalization characteristics. This deck provides for switching between two equalization curves: time constant 3180 μ s-70 μ s and 3180 μ s-120 μ s. When using tapes other than those listed below, it is possible that mismatching occurs.

Bias Adjustment

This deck provides bias adjustment controls, but the tapes from the list below can be used without adjustment. However, when wishing to perfectly match bias levels to the tape in use, you can perform the adjustment according to the following procedure. For adjustment, the 15 kHz (-20 dB) test tone of the deck's built-in test tone oscillator is used.

The oscillator produces the 15 kHz test tone at -20 dB, and it is recorded on the tape at this level, but the peak level meters read 0 dB at this time. To make for easier readings and permit accurate bias adjustment, the meter sensitivity is increased by 20 dB while using the 15 kHz test tone. (This does not apply for the 400 Hz test tone, which is produced and recorded on the tape at 0 dB, while the peak level meters read 0 dB in their normal mode.)

Adjustment Procedure

- ① Insert a cassette tape.
- ② Set the tape switches and the Eq switch according to the tape used. (Refer to the chart.)
- ③ Set the Dolby NR switch to "off".
- ④ Perform the record head azimuth alignment (→p. 12).
- ⑤ Next, perform the record level (sensitivity) calibration. Set the monitor switch to "source" and the test tone switch to "400" (400 Hz). Now the deck's peak level meters read "0 dB" for both channels. When the test tone switch is set to "400" or "15k", the L and R scale section shown by arrows in the chart changes to plus (+) and minus (-) 1 dB indication. When performing bias adjustment and record/play level calibration, use this scale for meter readings.

EX/120 μ sec Position

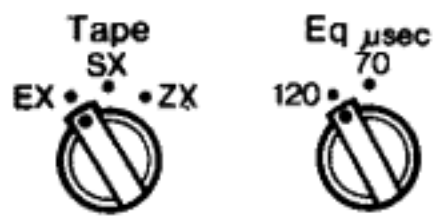
Selector Switches	Tape Used
	Nakamichi EXII Nakamichi EX TDK AD, OD Maxell UD, UDXL-I Fuji FX-I AMPEX GM-I

SX/70 μ sec Position

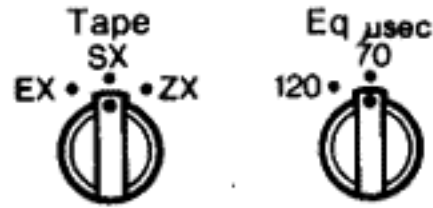
Selector Switches	Tape Used
	Nakamichi SX TDK SA Maxell UDXL-II Fuji FX-II AMPEX GM-II

ZX/70 μ sec Position

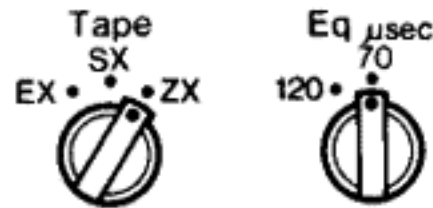
Selector Switches	Tape Used
	Nakamichi ZX TDK MA, MA-R Maxell MX Fuji Metal AMPEX MPT

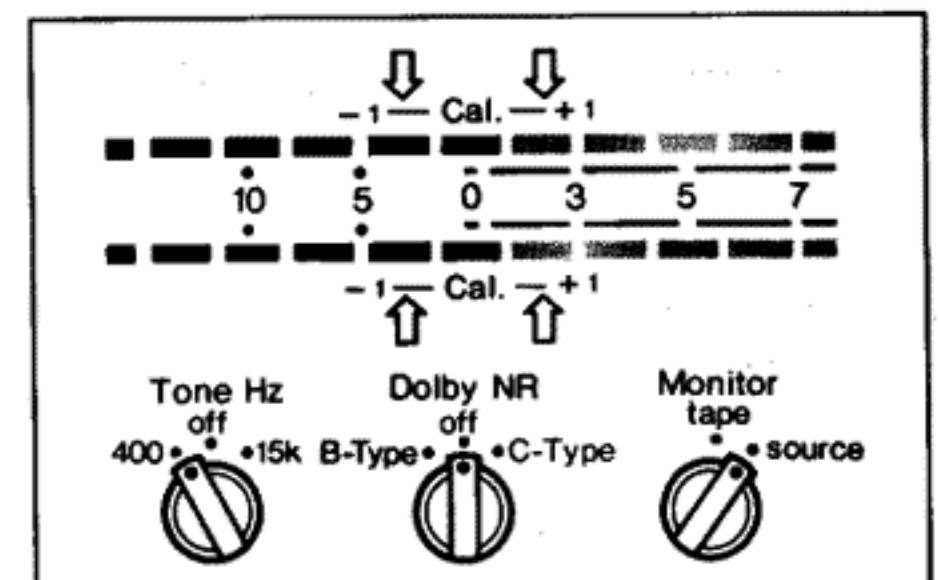

- ⑥ While depressing the record button, push the pause/cue button to put the deck into the record-standby mode.

- 7 Press the play button to start recording.
- 8 Set the monitor switch to "tape". The peak level meters now show the 400 Hz 0 dB test tone recorded on the tape.
- 9 If the meters do not indicate 0 dB at this time, adjust the appropriate record calibration controls using the small screwdriver supplied with the deck to obtain a 0 dB reading for left and right channels. Turn clockwise to correct a low reading. Turn counterclockwise to correct a high reading.

When the record level calibration is completed, push the pause/cue button once to return the deck to the record-standby mode, and then set the monitor switch to "source".

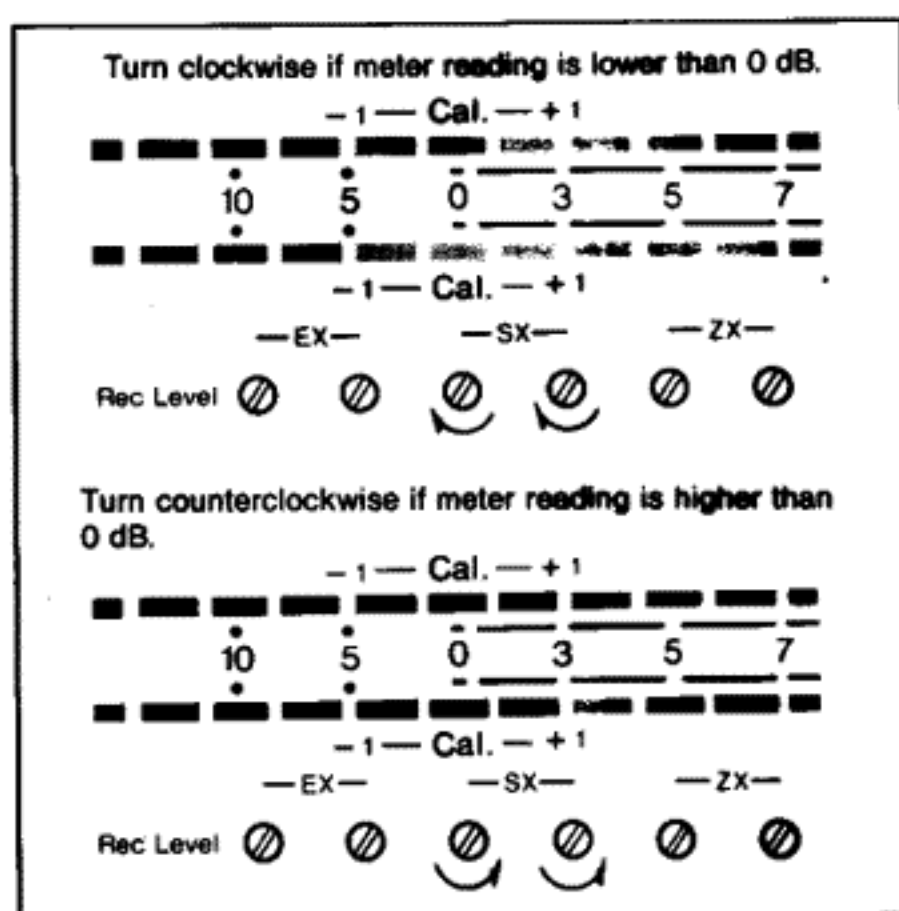
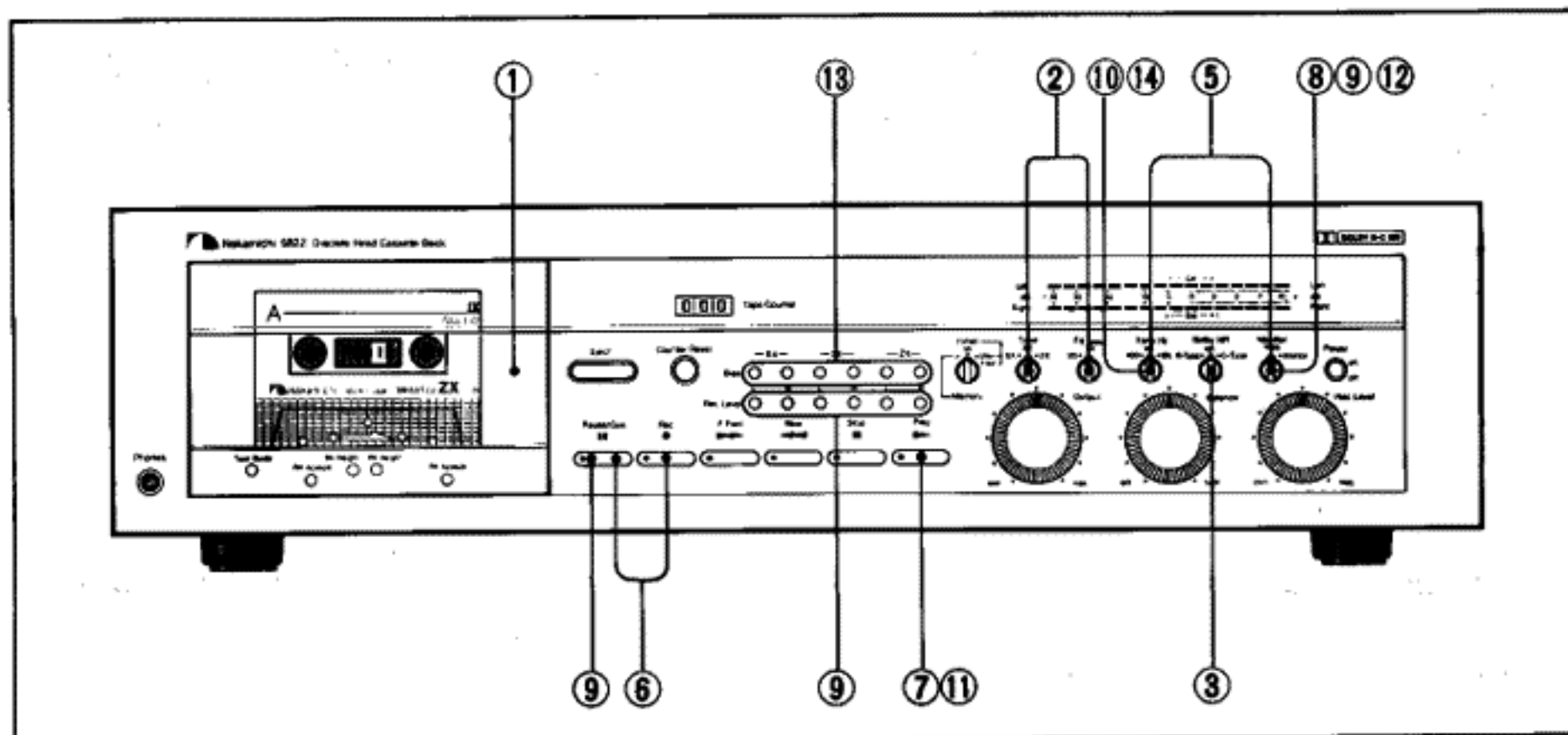

- 10 Next, set the test tone switch to "15" (15 kHz). In this condition, the peak level meters read "0 dB" for both channels. (The meters indicate "0 dB", but the actual level recorded on the tape is -20 dB.)

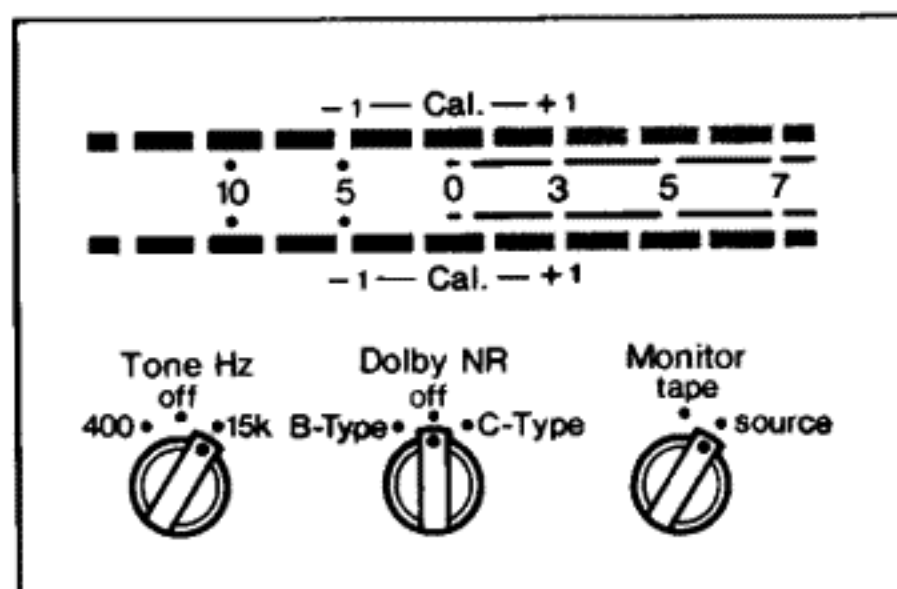

- 11 Press the play button to start recording.

- 12 Set the monitor switch to "tape". The 15 kHz test tone, which is being recorded on the tape at -20 dB, is played back and shown on the peak level meters with increased display sensitivity.
- 13 Using the small screwdriver supplied with the deck, slowly turn the bias controls corresponding to the respective tape switch position, until you obtain the highest meter readings for left and right channels. Next, turn the same controls slowly clockwise until the peak level meters both read 0 dB for left and right channels. This point provides the optimum bias setting for the tape in use.

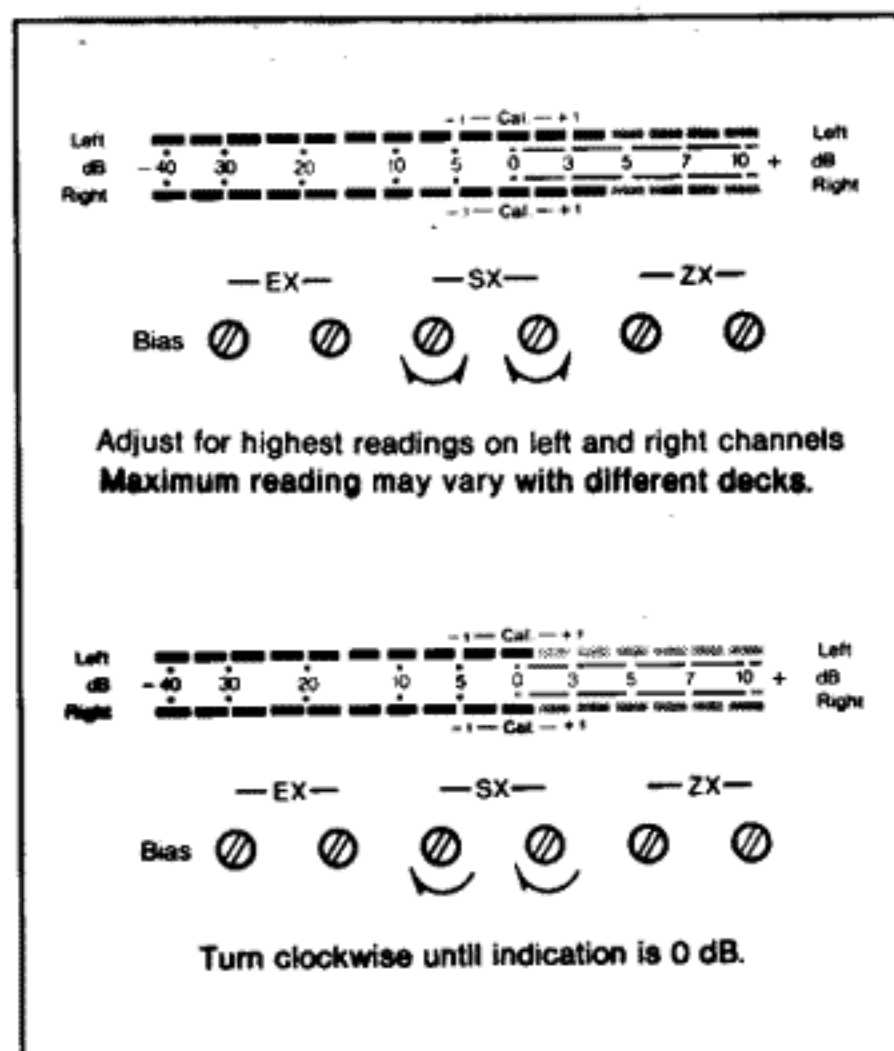

- 14 After performing the above adjustments, set the test tone switch to "off".

Note:

- The effects of turning the bias controls are displayed on the level meters only if the test tone is being recorded and the monitor switch is set to "tape". When the monitor switch is set to "source" or during ordinary playback the effects are not displayed on the meters.
- If tapes of inferior quality are used, the high frequency output may not increase even if bias is lowered (the controls are turned counter-clockwise), and only distortion will increase. Therefore, it is recommended to choose tapes from the list on p. 7.
- With some tapes, the meter indication may not exceed 0 dB also if the bias controls are turned. In such cases, merely set the controls at the 0 dB indication.
- Turn down the volume on your amplifier while using the test tone, because excessive high frequency signals could cause damage to the speakers.
- When using the test tone (400 Hz or 15 kHz), it is possible that meter indication is not exactly 0 dB even when the monitor switch is set to "source". This is due to the influence of temperature changes on the built-in oscillator, and does not consist a fault with the deck. In such a case, make the respective adjustment in such a way that the meter indication in the "tape" position reads the same as in the "source" position.

Dolby Noise Reduction System

This deck uses the Dolby Noise Reduction (NR) system, but with a difference: In addition to the Dolby B-Type Noise Reduction built into conventional cassette decks, it incorporates the newly developed Dolby C-Type Noise Reduction system.

Whereas the Dolby B-Type NR reduced noise in the high frequencies by about 10 dB, the Dolby C-Type NR with new characteristics achieves an improvement of about 20 dB in the range from 2 kHz to 8 kHz, where noise is most readily audible.

The operating principle of the Dolby C-Type NR is similar to the B-Type in that it does not affect high-level signals in recording, but processes only low-level signals in the mid and higher frequency range. However, the operation of the C-Type system starts at a point 2 octaves lower than with the B-Type and it incorporates new circuits to prevent encode/decode errors or high frequency loss due to tape saturation. By using the Dolby C-Type NR, dynamic range is greatly enhanced and the setting of record levels becomes easy and trouble-free.

This deck incorporates both the Dolby B-Type and the Dolby C-Type noise reduction systems. When playing back a tape from your collection which was recorded with the Dolby (B-Type) NR "on", the NR switch should be set to the "B-Type" position. When playing a tape recorded with the C-Type NR, the switch should be set to the "C-Type" position.

Note:

- This system does not reduce any noise already contained in the incoming input signal. You should therefore use signals as noise-free as possible as recording sources.

To the ear, the Dolby C-Type NR system provides a constant noise reduction with any type of music, during signal as well as during silent passages. Modulation or "breathing" noise has been suppressed past audibility, and the tape's saturation level is increased by the action of the so-called "spectral skewing circuit" to determine pre-emphasis and de-emphasis, and the "Anti-Saturation Network (ASN)", etc.

Chart A illustrates low-level encoding characteristics for the B-Type NR and the C-Type NR. Decoding is done with exactly opposite characteristics, thus achieving flat overall frequency response. As can be seen from the chart, the operation threshold of the C-Type is two octaves lower than that of the B-Type, and in the high frequency range reduction is by 20 dB.

Chart B shows the actual frequency response and noise spectrum analysis as recorded on a cassette deck. It is evident from the noise spectrum analysis that with the C-Type NR noise is considerably lower than with the B-Type; it is reduced by about 20 dB in the frequency range from 2 kHz to 8 kHz. In addition, with the C-Type NR the ASN and skewing features etc. serve to increase the high frequency MOL during high-level recording.

Low-level Encoding Characteristics (Less than -60 dB)

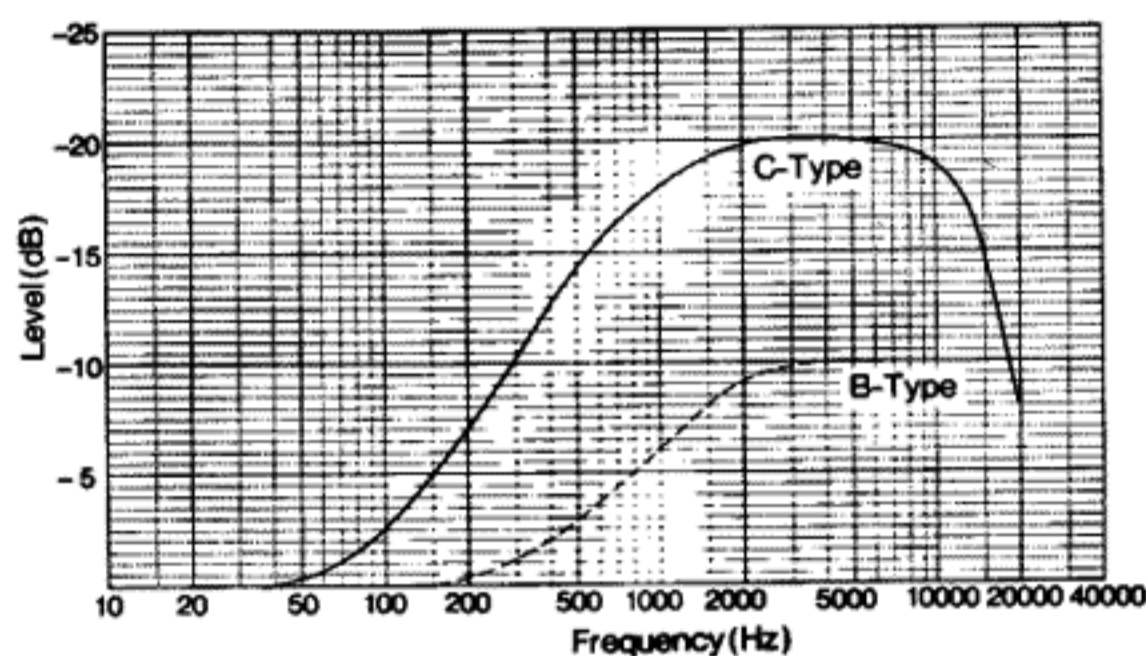

Chart A

Frequency Response and Noise Spectrum Analysis

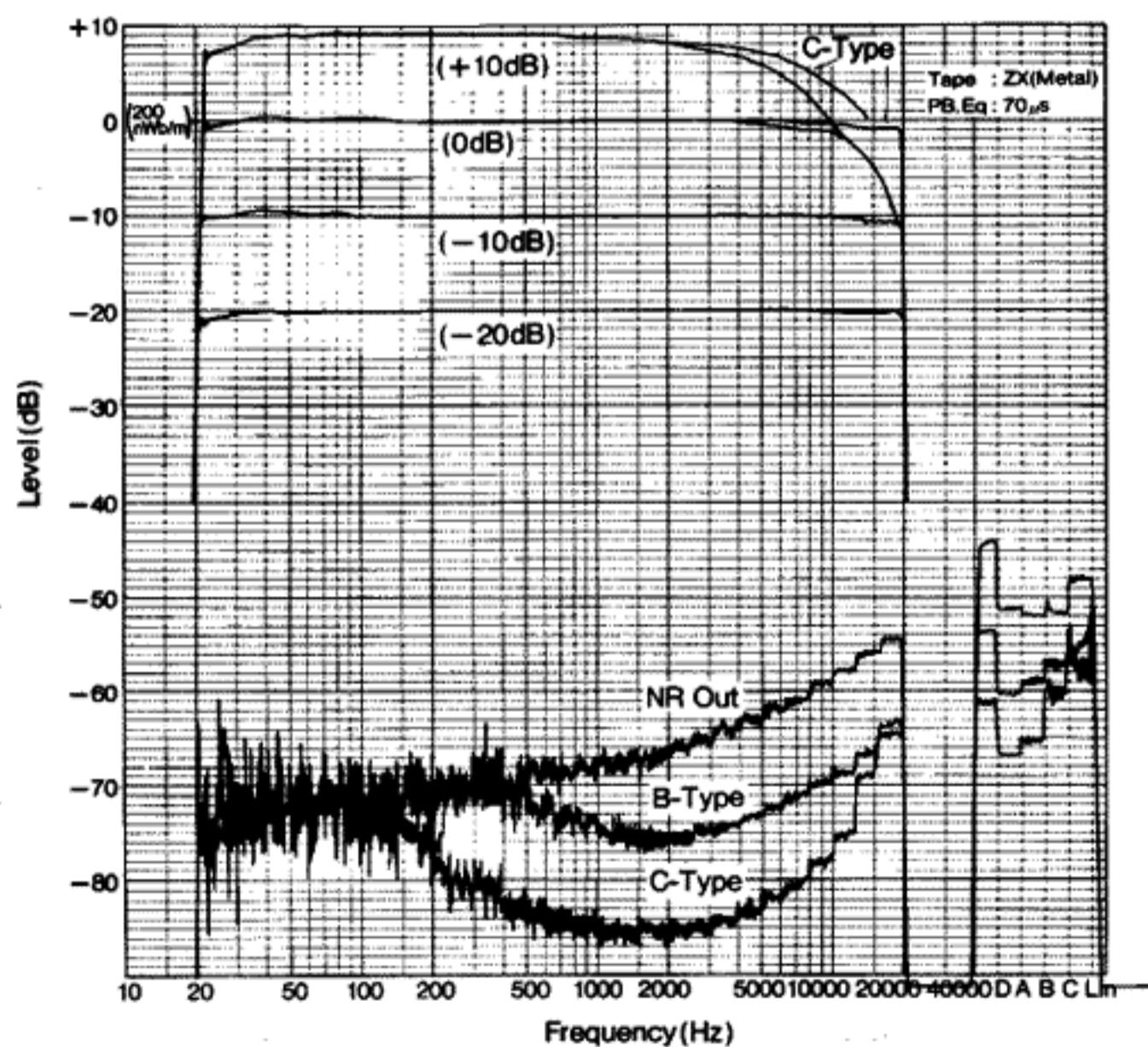

Chart B

Record Level Calibration

As is evident from the description of the Dolby principle, when using the Dolby noise reduction system it is necessary to perform record calibration to assure that a tone recorded with 0 dB will also play back at 0 dB, regardless of the sensitivity of the tape used. If this adjustment is not performed, the level difference resulting when a tape with a different sensitivity is used, can lead to Dolby mis-tracking and thus impair sound quality. To permit easy level calibration, this deck incorporates a test tone oscillator of 400 Hz, 0 dB. In addition, the discrete 3-head configuration of this deck lets you read the playback level of the test tone while it is being recorded. Thus the adjustment can be performed easily while looking at the meter readings.

When the same brand of tape is used continuously, it is not necessary to perform repeated level calibration. Only if you are changing brands (say from EX tape to EX II tape) should the calibration be performed.

Calibration Procedure

- ① Insert a cassette tape.
- ② Set the tape switch and the Eq switch according to the tape used. (→p. 7)
- ③ Set the Dolby NR switch to "off".
- ④ Set the monitor switch to "source" and the test tone switch to "400" (400 Hz). Now the peak level meters read "0 dB" for both channels.

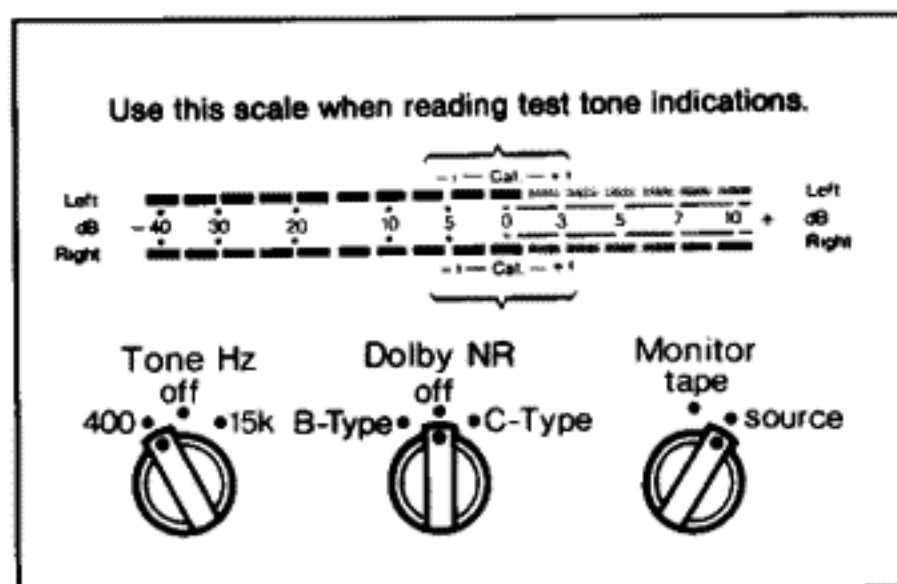

- ⑤ While depressing the record button, push the pause/cue button to put the deck into the record-standby mode.
- ⑥ Press the play button to start recording.
- ⑦ Set the monitor switch to "tape". The peak level meters now show the 400 Hz 0 dB test tone recorded on the tape.

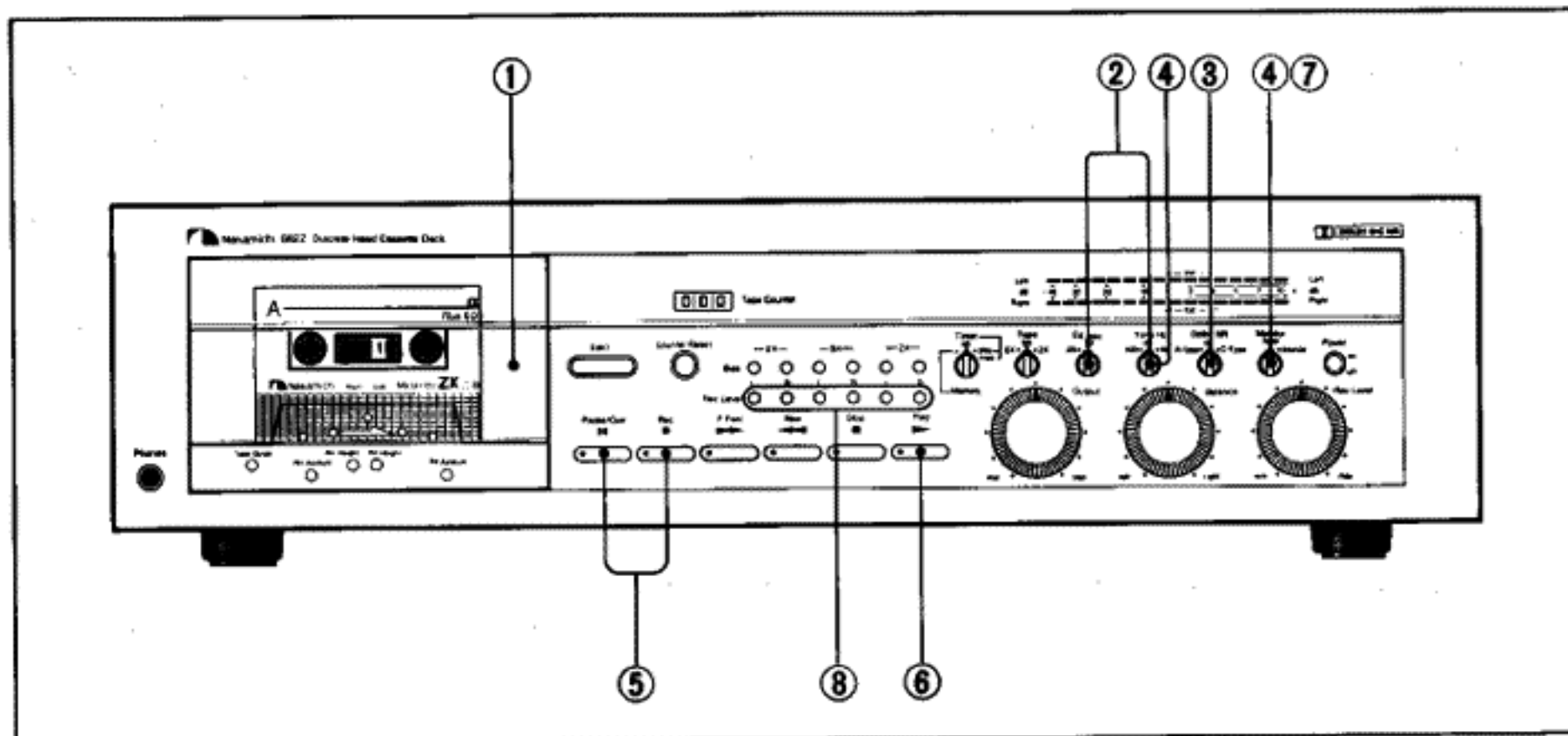

- ⑧ If the meters do not indicate 0 dB at this time, adjust the record calibration controls corresponding to the respective tape switch position, using the small screwdriver supplied with the deck, to obtain a 0 dB reading for left and right channels. Turn clockwise to correct a low reading. Turn counter-clockwise to correct a high reading.

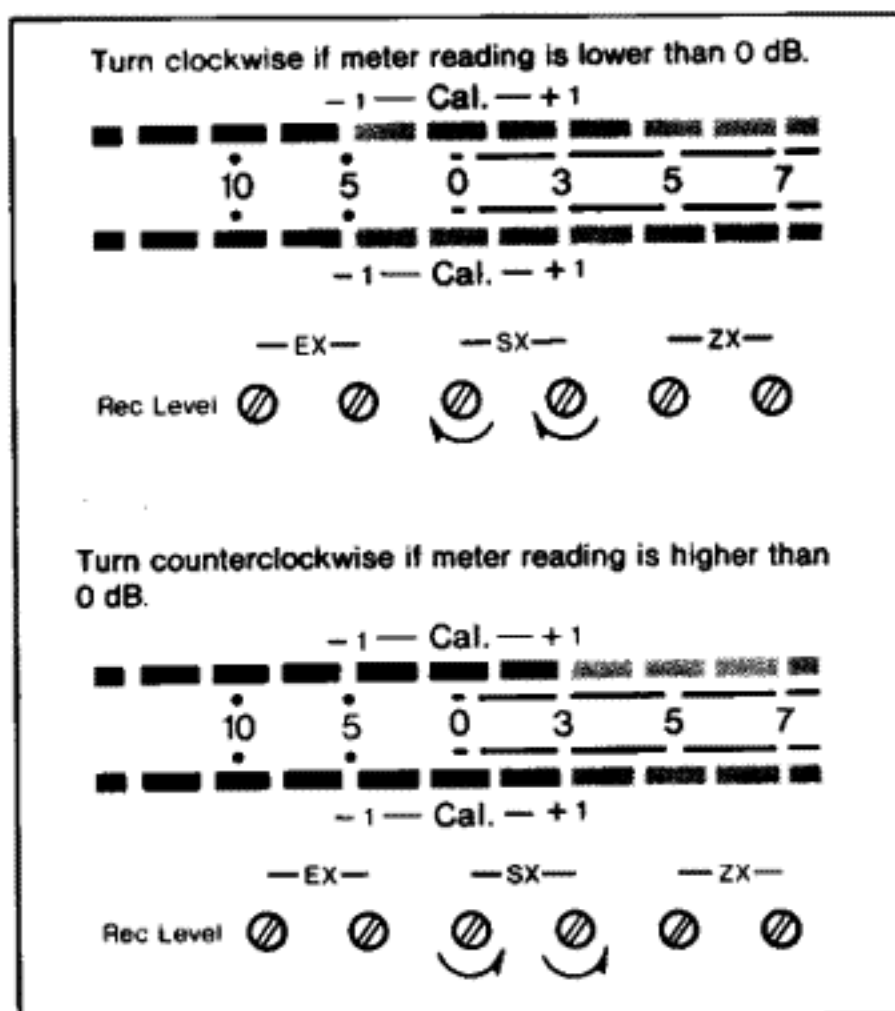

Note:

- The effects of turning the record calibration controls are displayed on the level meters only if the test tone is being recorded and the monitor switch is set to "tape". When the monitor switch is set to "source" or during ordinary playback the effects are not displayed on the meters.

The Nakamichi T-100 Audio Analyzer (optionally available) is a most useful tool for all kinds of tape deck adjustments and measurements. With one T-100 it is possible to perform measurement and adjustment of frequency response, distortion, wow and flutter, etc.

T-100 Audio Analyzer

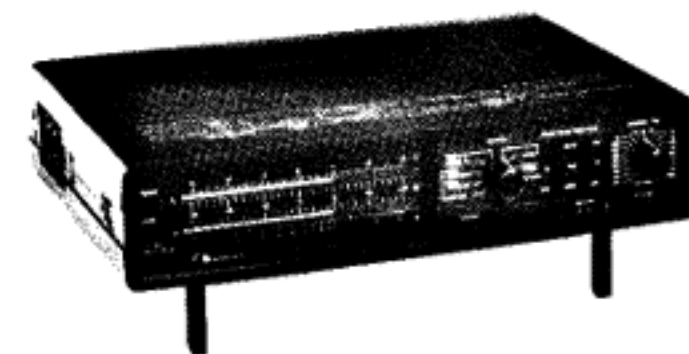

Recording

Prior to starting a recording, be sure to consult the preceding paragraph "Before Recording".

- ① After confirming that the tape start memory/timer switch is set to "off" or "memory", turn on the power by pushing the power switch.
- ② Open the cassette compartment lid by pushing the eject button.
- ③ Load the cassette into the lid from the top. Then close the cassette lid by pushing it gently back into the panel.
- ④ Set the monitor switch to "source".
- ⑤ Set the Eq and tape selector switches as required. (→p. 7)
- ⑥ When wanting to use the Dolby system for recording, set the Dolby NR switch to the desired position, either "B-Type" or "C-Type".
When recording from FM broadcasts, set the MPX filter switch on the rear panel to "In".

Note:

- Use the MPX filter only when recording from FM broadcasts.
- ⑦ Press the tape counter reset button. The tape counter should now read 000.
- ⑧ Confirm that the test tone switch is in the "off" position.
- ⑨ To put the 582Z into the record-standby mode, press and hold the record button with one finger; while holding this button, press the pause/cue button. The red lamp above the record button will light to indicate the record mode.
- ⑩ You are now ready to set the input (record) levels. Use the input level control while playing a portion of your program source to obtain readings on the peak level meter. The balance control is normally left in its center-dentend position, but it may be used to correct imbalance of input levels. See the section entitled "Tips on Setting Record Levels" (page 13) for more detailed information on this procedure.
- ⑪ To commence recording once levels are set, simply press the play button.
- ⑫ If you wish to check the quality of a recording in progress, you can monitor the playback signal by setting the monitor switch to "tape".
- ⑬ To halt recording temporarily, press the pause/cue button. Press the play button again when you are ready to resume recording.
To stop recording altogether, push the stop button.

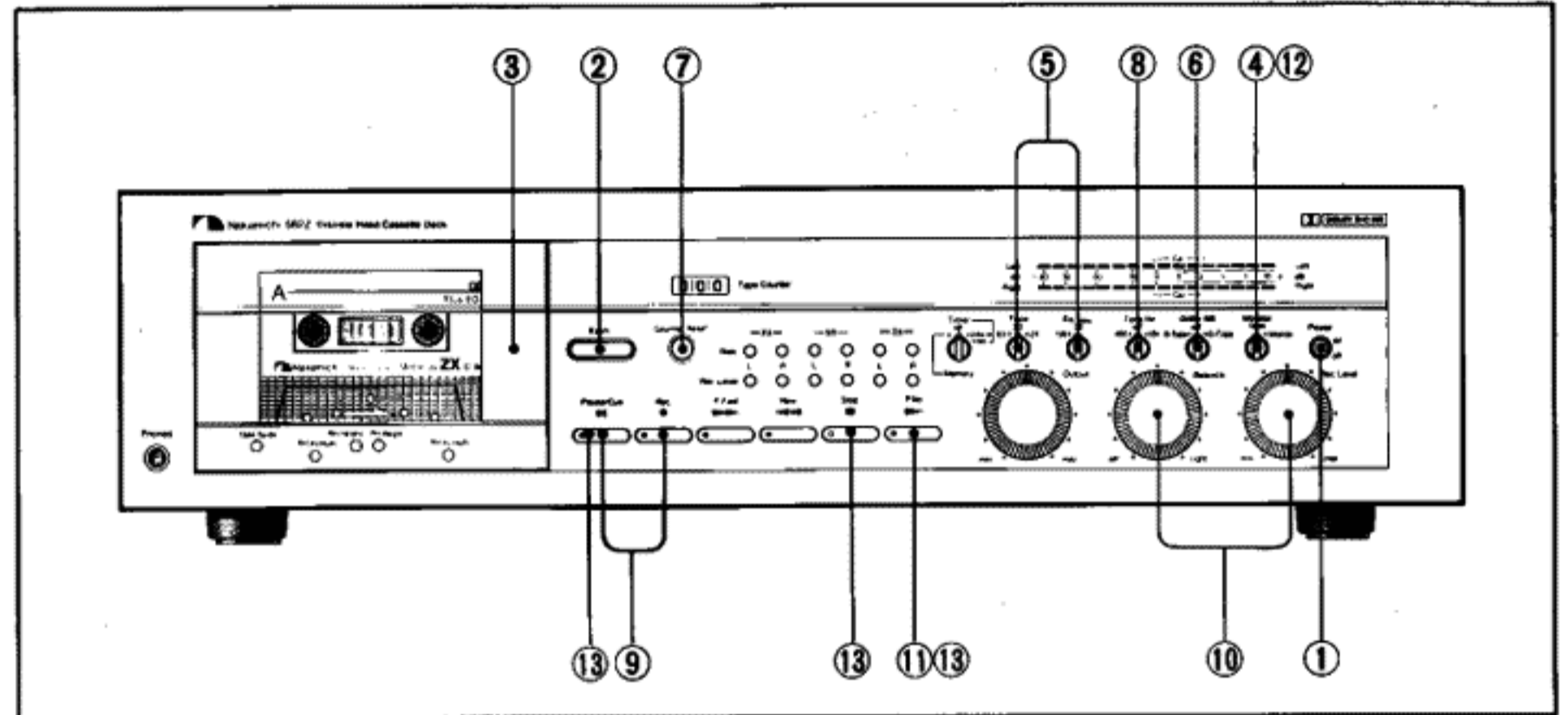

Timer Operation

The 582Z has a built-in self-start feature which enables you to make unattended recordings or to start playback at a preselected time with the use of a timer.

1. Make connections as shown in the chart.
2. Insert the tape to be recorded or played and turn on the power to all components.
3. For unattended recordings, adjust the line input level control to suit the expected recording level; for automatic playback adjust the output level control to the desired level. Check if all components are set up properly.
4. For unattended recording, set the tape start memory/timer switch to "rec"; for playback set it to "play".

5. At the pre-selected time, the timer will supply power to the components and the 582Z will start recording or playing.

Remote Control

It is possible to operate this deck from a remote location by using the optionally available remote control unit RM-200 (cable length 5 m).

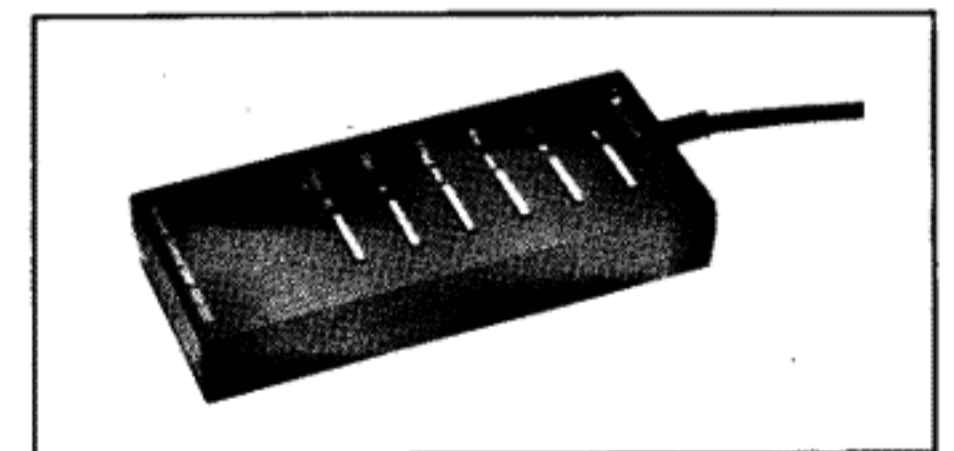

Rec Mute Function

By pushing the record button (Rec) once more during recording, the recording signal is muted as long as the button is being depressed. This can be used to cut off unwanted portions while recording from FM broadcasts, etc. As the line output is not affected, it is possible to monitor the signal during the mute operation.

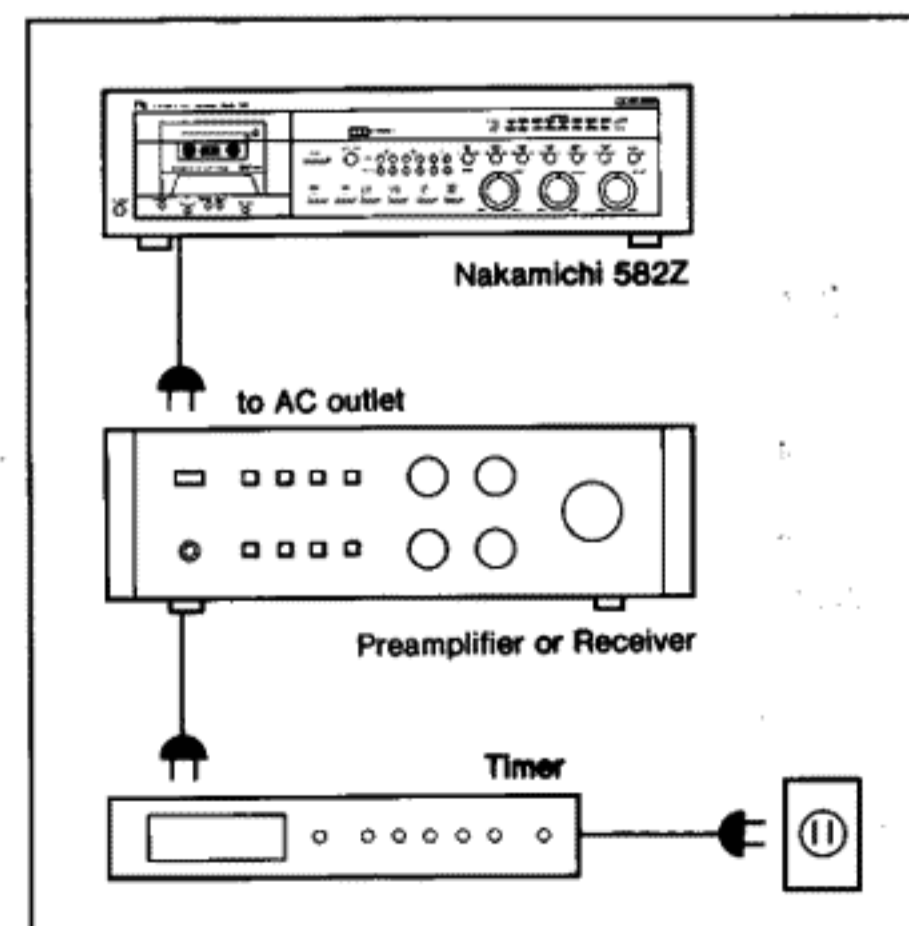

Record Head Azimuth Alignment

"Azimuth" denotes the degree to which the gap of a magnetic head is perpendicular to the path of tape travel. Azimuth misalignment causes degradation of phase characteristics and impairs high-frequency response. Especially with a high-performance discrete 3-head cassette deck like the 582Z, it is important that the critical play head and record head azimuth angles be aligned perfectly with every tape. The heads of this cassette deck have been factory-aligned for best performance. Thus ordinarily, realignment is not necessary. However, external factors such as slight differences in cassette housings, etc. may cause minor misalignment. To compensate for this, we recommend to perform record head alignment by means of the "RH Azimuth" screw. (Warning: As the play head azimuth serves as a fixed standard in this procedure, you should never touch the "PH Azimuth" screw! Playback azimuth alignment should only be performed by authorized service centers.)

Record head azimuth alignment should be carried out:

- before performing bias adjustment (→p. 7).
- if the tape sounds dull in comparison to the original signal.
- before a recording of particular importance.

Record Head Azimuth Alignment Procedure

1. Insert the cassette to be used and fast-forward the tape for some time, then press the stop button.
2. Set the tape switch and the Eq switch according to the tape in use. (→p. 7)
3. Set the Dolby NR switch to "off".
4. Set the test tone switch to "15" (15 kHz).
5. Set the monitor switch to "tape".
6. While depressing the record button, push the play button to start recording.
7. Take the small screwdriver supplied with the deck and insert it gently into the opening marked "RH-Azimuth" on the lower portion of the cassette compartment lid. Turn the screwdriver slightly until the tip engages with the screw slot.
8. While exerting minimal pressure on the screwdriver, turn it very slowly while watching the peak level meters. Reverse direction if the meter readings decrease. Adjust for a maximum reading on both meters.

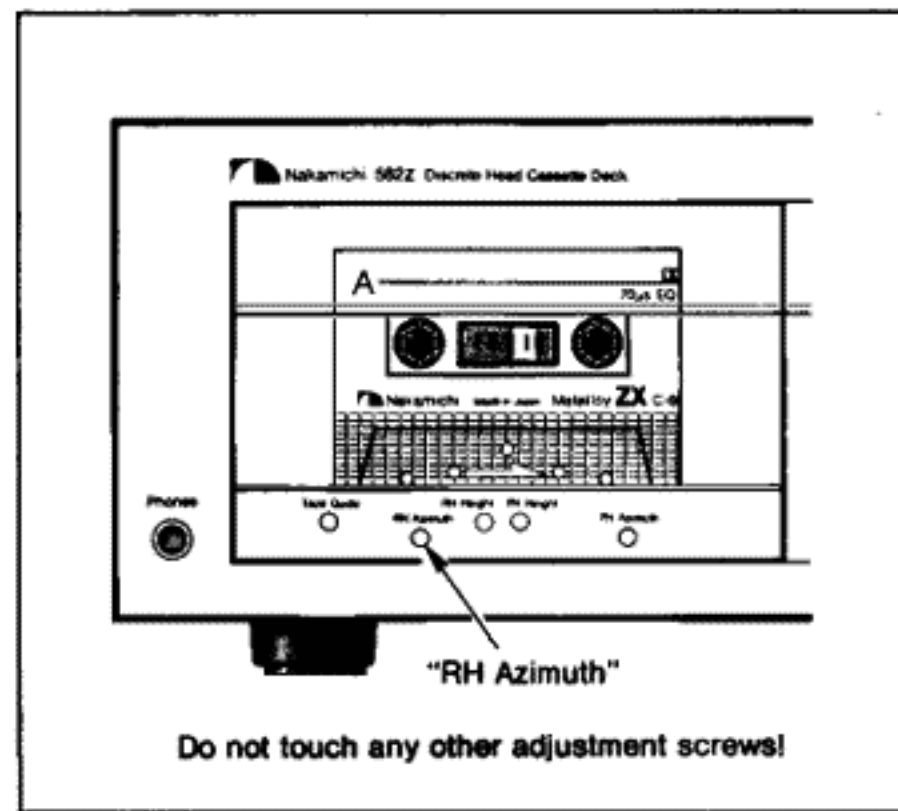

Note:

- Never push the stop, rewind or fast forward buttons etc. while the screwdriver is inserted or engaged.
- Dirty heads or capstans will render a correct adjustment impossible.

Tips on Setting Record Levels

For good recordings, it is essential to maintain a high signal-to-noise ratio. This is achieved by putting as much signal on the tape as is possible without producing distortion. Setting record levels too low will result in noisy recordings, while too high recording levels drive the tape into saturation and cause distortion. Finding the proper level between these two extremes is what good recording is all about.

This deck provides 50 dB full range peak level meters, which display even very short signal peaks with great accuracy. Refer to the chart as a guideline to set recording levels.

"Normal" (LH) position tape formulations, "Chrome" position tape formulations:

The meters should be allowed to read as high as +5 dB on short program peaks.



"Metal" position tape formulations:

The meters should be allowed to read as high as +8 dB on short program peaks.

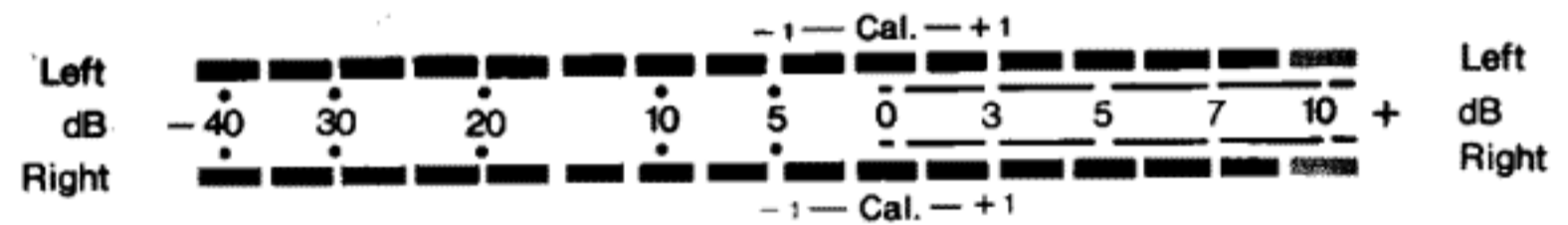

As different tape formulations have slightly different overload (headroom) characteristics, the requirements may vary to a certain degree when using different tapes.

Head and Transport Cleaning

To maintain the Nakamichi 582Z's superior performance and to prolong the life of the heads and pressure rollers, all parts which come into contact with the tape should be cleaned frequently and thoroughly. Dirty heads, capstans or pressure rollers may result in any of the following symptoms:

- Uneven sound levels.
- Loss of high frequencies.
- Wow and flutter.
- Damage to cassette tapes.
- Tape squeal caused by excess friction.

Even the best cassettes shed particles onto the heads, capstans and pressure rollers. Clean a minimum of once every ten hours of use, even if you use premium tapes. If you must use inferior brands of tape, you may need to clean after each playing. By observing the amount of contamination accumulated on the cleaning stick pad or cotton tip, you will be able to judge whether you are cleaning the 582Z frequently enough. Repeated cleanings, if properly done, will not harm the deck. Hence, it is impossible to clean too often.

A Cleaning Kit consisting of a plastic stick, sponge tips, cotton tipped sticks and a container of alcohol is supplied with your Nakamichi 582Z. When the alcohol runs out, use commercially available isopropyl alcohol (preferably undiluted). "Q-tips" and other cotton swabs may be used in the place of the sponge tips. Do not, however, rely on head cleaning cassettes. Some head-cleaning cassettes are unduly abrasive and may damage the heads. None of them clean the capstans and pressure rollers properly. Perform all cleaning with alcohol. Use the plastic stick with a sponge tip screwed onto its end. A cotton-tipped stick is equally effective, but be careful not to leave strands of cotton on any of the cleaned parts.

Clean in the following sequence:

(A) Turn the power switch on. Push the eject button to open the cassette lid. Carefully pull the acrylic cassette compartment cover out of the cassette lid. Push the cassette lid back into its well.

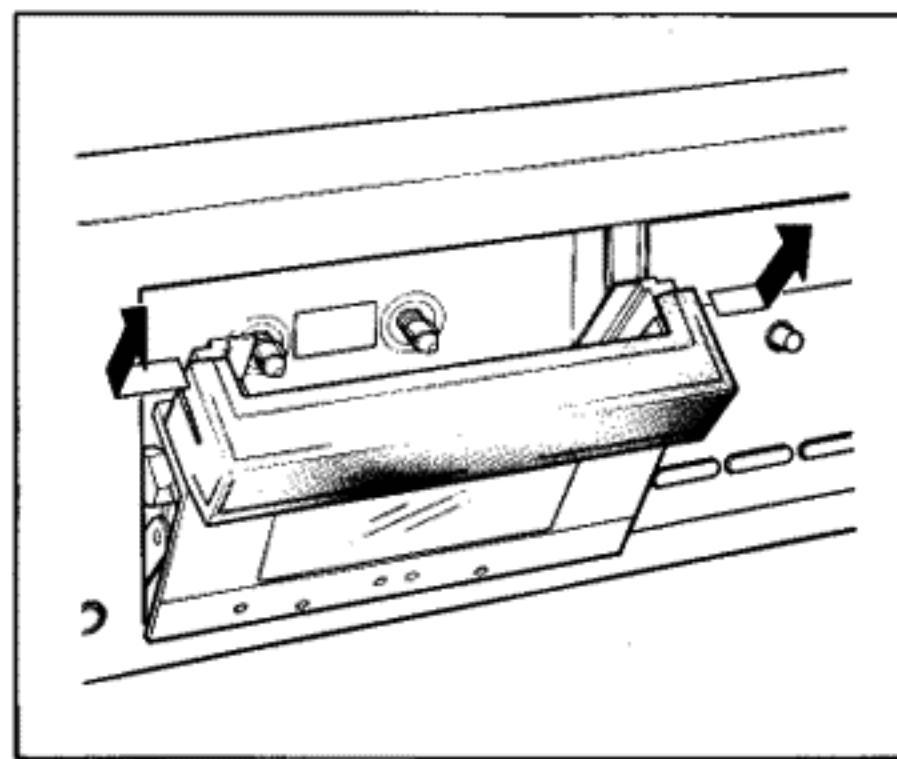

(B) With a cleaning stick dipped in alcohol, clean the surfaces of the record, playback and erase heads. Clean with short, firm back-and-forth strokes along the path of tape travel. Also be sure to clean the tape guide on the far left.

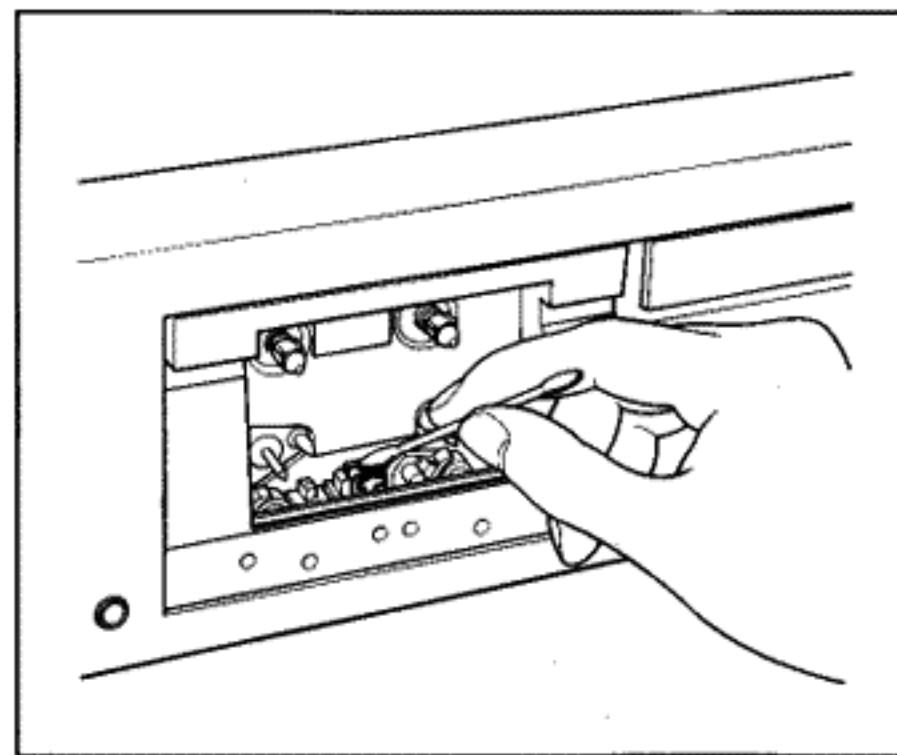

(C) Press the play button. Carefully apply the cleaning stick to one pressure roller as it turns. Use light pressure and an up-and-down stroke to cover the entire width of the roller. Repeat with the other pressure roller. If you are using a cotton-tipped stick, make sure to apply the tip to the side of the roller rotating away from the capstan; the cotton may otherwise get caught between the capstan and the roller (if this should happen, simply press the stop button and remove the cotton).

(D) With the transport in the stop mode, apply a clean section of the cleaning stick pad to one capstan. Move the pad up and down the capstan shaft as it turns. Repeat with the other capstan.

(E) Press the eject button, and carefully re-insert the acrylic cover.

Cleaning is now completed, but give the cleaned surfaces a minute or two to dry off completely before playing a tape.

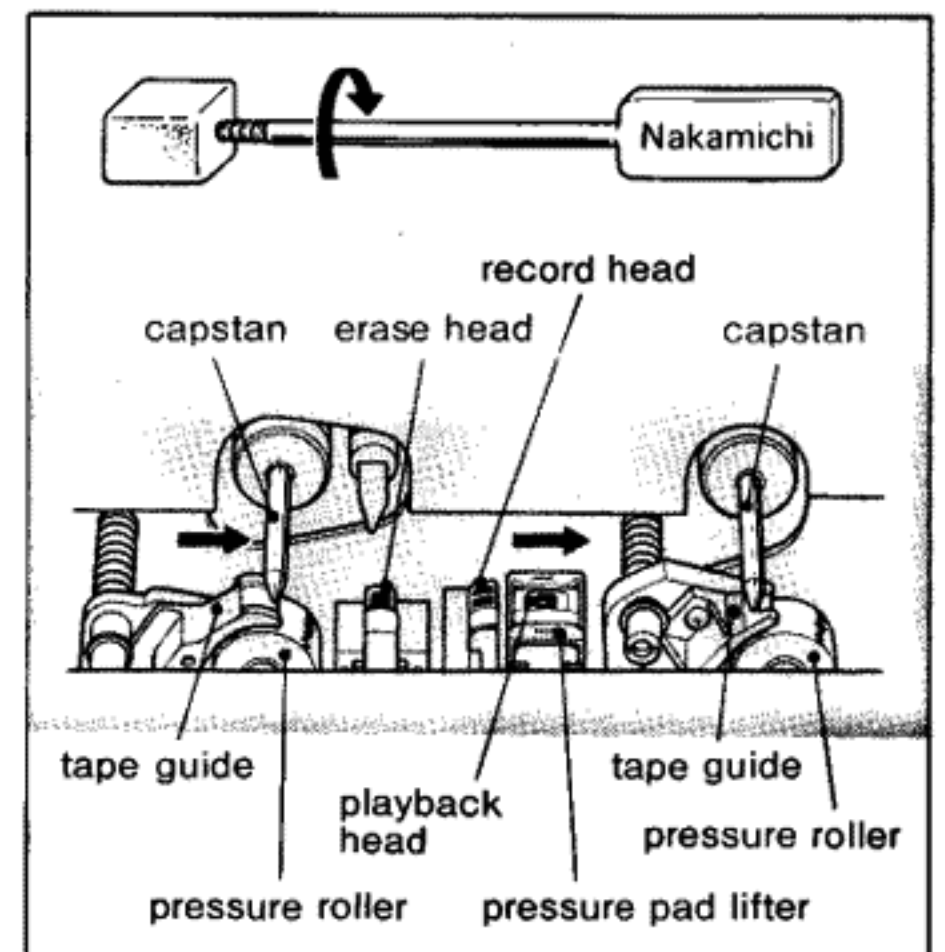

CAUTION:

- Tape guide and heads are critically aligned at the factory. Do not exert too much pressure on these parts. It is better to stroke repeatedly than to stroke forcefully.
- Do not flood various parts with cleaning alcohol. After dipping the stick into alcohol, squeeze off any excess.
- Be sure to remove any cotton strands from the cleaned parts.

Demagnetizing

All metal parts that come into contact with the tape must be occasionally demagnetized to prevent the build-up of residual magnetism. Such magnetism can add hiss to a tape being played and partially erase the high frequencies. Although the heads and capstans of Nakamichi cassette decks require demagnetizing less frequently than those of most other cassette decks, you should nevertheless demagnetize once every 50 hours of use to be on the safe side. The Nakamichi DM-10 Demagnetizer is recommended since it has been specifically designed for cassette decks, but any properly designed demagnetizer will do.

- (A) Remove all tape from the vicinity of the tape deck before proceeding. Make sure the 582Z's power switch is off. Remove the cassette compartment cover. Push the cassette lid back into its well.
- (B) Turn the demagnetizer on while it is at least two feet away from the deck. Slowly bring the tip as close as possible to the playback head. Do not make contact with the head unless the tip of the demagnetizer is covered with vinyl or rubber to prevent scratching the head's surface. A piece of vinyl tape may be used to cover the tip if it is not already covered.

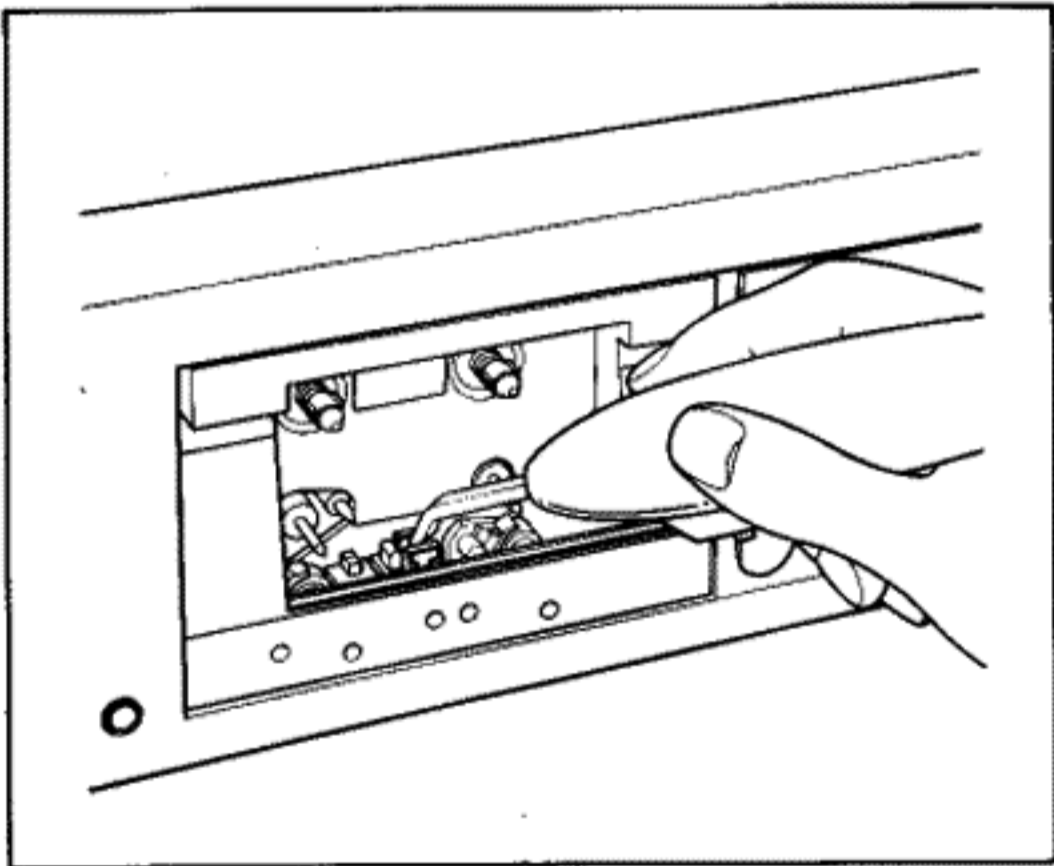

- (C) Move the demagnetizer slowly in a random pattern about the surface of the head for at least 10 seconds. Move it slowly to the record head and repeat the random pattern. Then, move the demagnetizer to one capstan then the other, repeating the random pattern for 10 seconds. (It is not necessary to demagnetize the erase head.)

- (D) After demagnetizing the capstans, slowly withdraw the demagnetizer from the deck. Wait until the demagnetizer is at least two feet from the deck before turning the demagnetizer off. Never turn it off while it is close to a head or capstan as this may semi-permanently magnetize the part.

Lubrication

The moving parts of the Nakamichi 582Z transport are fitted with oil-less bearings. Periodic lubrication is not necessary.

Cleaning the Faceplate

Remove dust or smudges with diluted detergent applied with a soft-cloth. Never use solvents, ammonia, or abrasive cleaning agents.

Head Height

The head height adjustments of the Nakamichi 582Z are calibrated at the factory for optimum performance. Readjustment should only be done by qualified service technicians.

Repairs

Your Nakamichi 582Z has been designed for long service life. Should your 582Z require servicing, please consult your Nakamichi dealer or the Nakamichi dealer nearest you. As there are no user-serviceable parts inside the unit, please do not attempt your own repairs.

Condition	Probable Cause	Remedy
Tape does not run.	<ol style="list-style-type: none"> 1. Power cord is unplugged. 2. Cassette is not properly seated. 	<p>Plug in cord firmly. Eject and re-insert cassette.</p>
Cannot record.	<ol style="list-style-type: none"> 1. Input disconnected. 2. Head dirty. 3. Cassette tabs have been removed. 	<p>Check connections. Clean head. Place adhesive tape over tab opening or use new cassette.</p>
Cannot playback.	<ol style="list-style-type: none"> 1. Output disconnected. 2. Dirty head. 	<p>Check connections. Clean head.</p>
Excessive playback hiss.	<ol style="list-style-type: none"> 1. Head is magnetized. 2. Recording volume is too low. 	<p>Demagnetize head. Adjust recording levels.</p>
Distorted playback.	<ol style="list-style-type: none"> 1. Program material itself is distorted. 2. Recording levels are too high. 	<p>Check program material. Adjust recording levels.</p>
Unsteady tape travel	<ol style="list-style-type: none"> 1. Capstan and/or pressure roller dirty. 2. Tape packing inside cassette faulty. 	<p>Clean these parts. Replace cassette.</p>
Incomplete erasure.	Erase head is dirty.	Clean head.
Weak high frequencies.	<ol style="list-style-type: none"> 1. Dirty heads. 2. Magnetized head. 3. Record head azimuth misalignment. 	<p>Clean heads. Demagnetize head. Perform record head azimuth alignment as described on p. 12.</p>
Hum heard during record or playback.	<ol style="list-style-type: none"> 1. Induction fields near deck. 2. Signal cable grounding faulty. 	<p>Keep deck away from amplifier, transformers, fluorescent lamps, etc. Replace signal cables.</p>

Specifications

Specifications:

Power Source.....	100, 120, 120/220-240, 220 or 240 V AC ; 50/60 Hz (According to country of sale)
Power Consumption.....	30W Max.
Tape Speed.....	1-7/8 ips. (4.8 cm/sec.) \pm 0.5%
Wow and Flutter	Less than 0.1% WTD Peak, 0.05% WTD rms
Frequency Response.....	20-20,000 Hz \pm 3 dB (-20 dB Rec. Level)
Signal to Noise Ratio.....	C-Type NR on (70 μs, ZX Tape) Better than 72 dB at 400 Hz, 3% THD, IHF A-wtd rms B-Type NR on(70 μs, ZX Tape) Better than 66 dB at 400 Hz, 3% THD, IHF A-wtd rms
(Dolby NR In, 70 μ s)	Less than 0.8% at 400 Hz, 0 dB (ZX Tape) Less than 1.0% at 400 Hz, 0 dB (SX, EXII Tapes)
Total Harmonic Distortion.....	Better than 60 dB below saturation level at 1 kHz
Erasure.....	Better than 37 dB at 1 kHz, 0 dB
Separation.....	Better than 60 dB at 1 kHz, 0 dB
Crosstalk	105 kHz
Bias Frequency	50 mV, 50 k ohms
Input	1V (400 Hz, 0 dB, Output Level at Max.) 2.2 k ohms
Output Level.....	45 mW
Headphone	\pm 10V 125 mA Max.
DC Output Jack.....	500(W) \times 130(H) \times 350(D) mm
Dimensions	19-11/16(W) \times 5-1/8(H) \times 13-25/32(D) inches
Approximate Weight.....	8.3 kg, 18 lb. 5 oz

- Specifications and appearance design are subject to change for further improvement without notice.
- Dolby NR under license from Dolby Laboratories.
- The word "DOLBY" and the Double-D-Symbol are trademarks of Dolby Laboratories.

Optional Accessories

ZX Cassette Tape C-60, C-90
 SX Cassette Tape C-60, C-90
 EXII Cassette Tape C-60, C-90
 EX Cassette Tape C-60, C-90

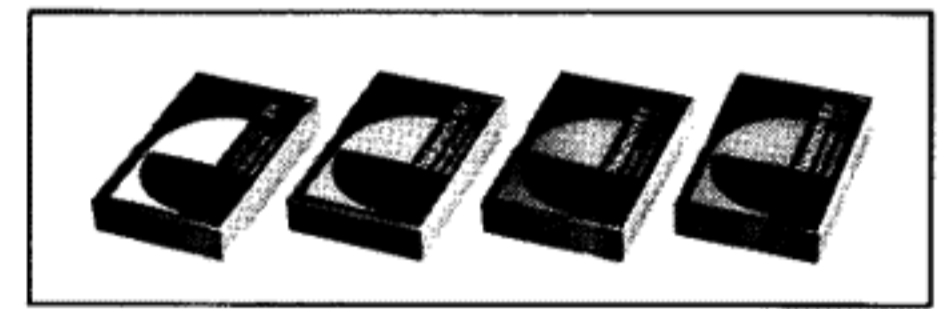

RM-200 Remote Control

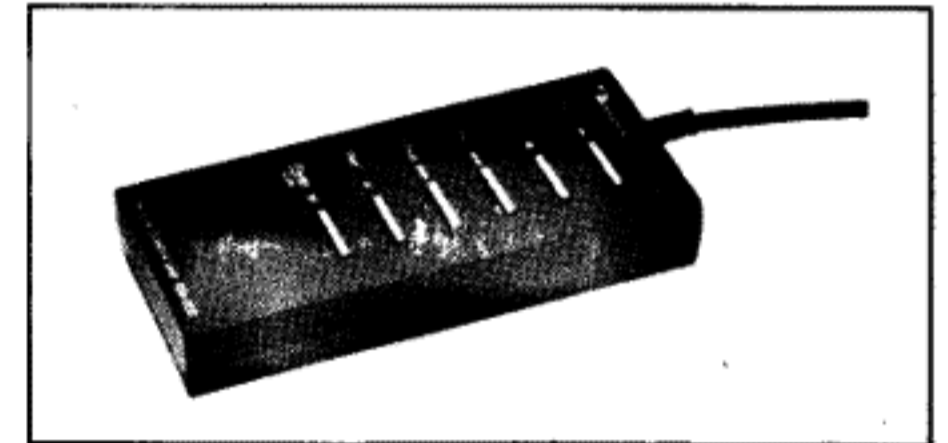

MX-100 Microphone Mixer

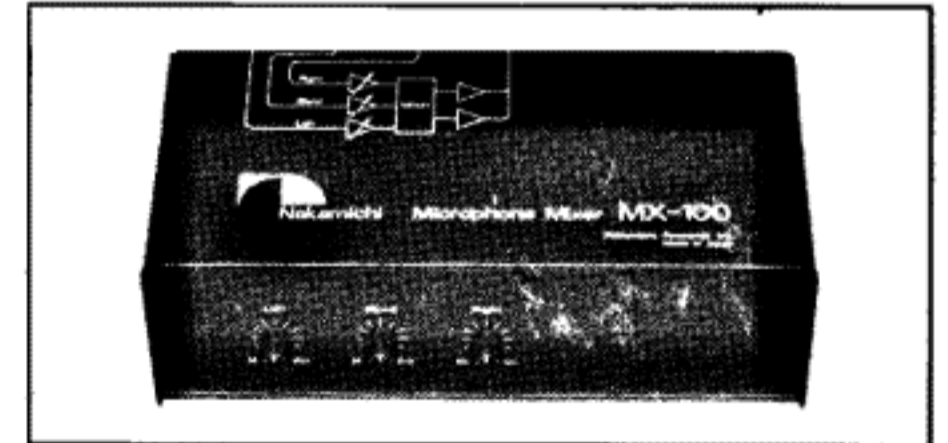

DM-10 Head Demagnetizer

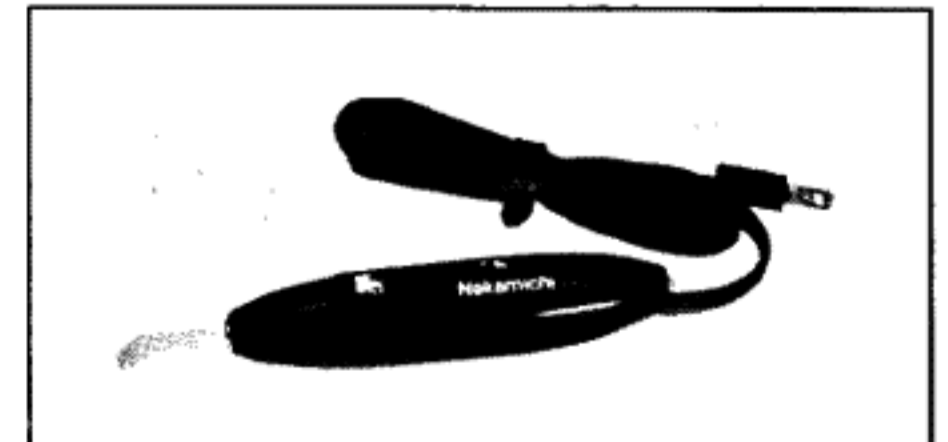

Nakamichi Corporation
 1-153 Suzukicho, Kodaira, Tokyo
 Phone : (0423) 42-1111
 Telex : 2832610 (NAKAM J)
 Cable : NAKAMICHI KOKUBUNJI

Nakamichi U.S.A. Corporation
 220 Westbury Avenue
 Carle Place, N.Y. 11514
 Phone : (516) 333-5440

Nakamichi U.S.A. Corporation
 1101 Colorado Avenue
 Santa Monica, Calif. 90401
 Phone : (213) 451-5901
 Telex : 652429 (NAKREI SNM)